

Replacement Parts List for Model # 610

01 DISCHARGE/TAKEUP COMPLETED BOLTED ASSEMBLY

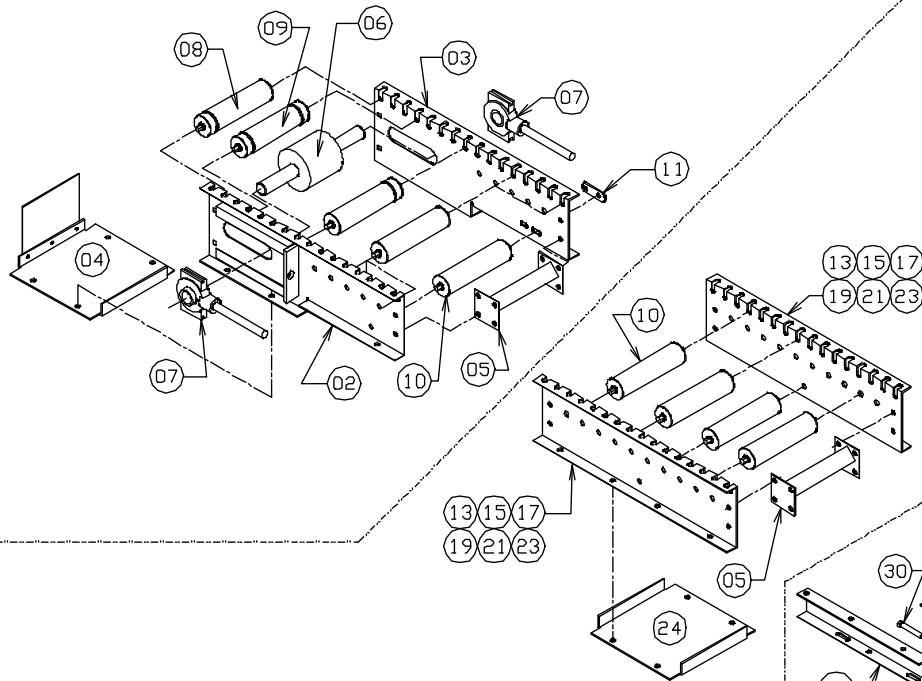

12 14 16 18 20 22 INTERMEDIATE COMPLETED BOLTED ASSEMBLY

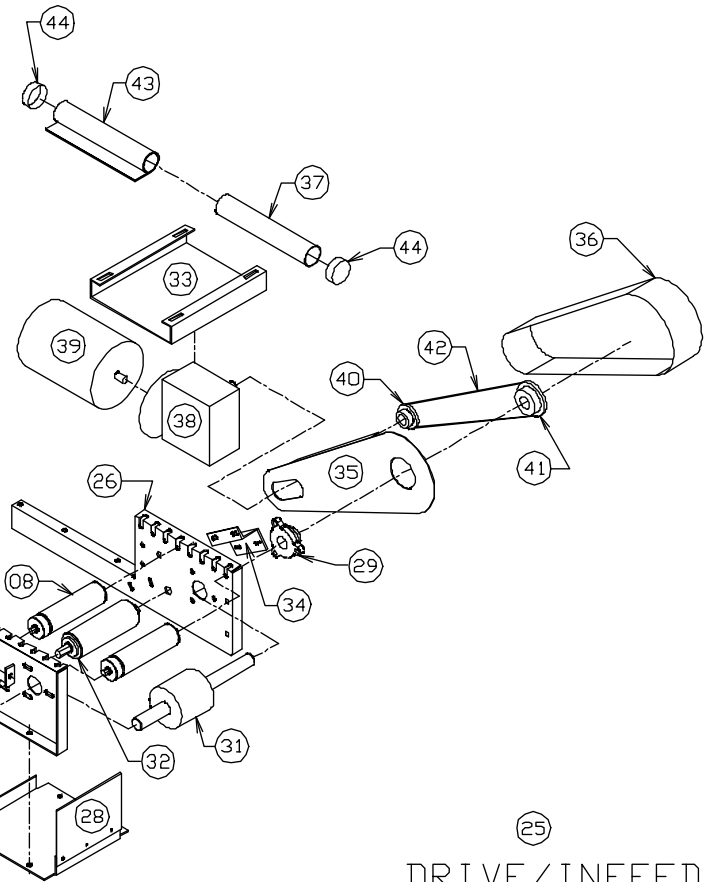

25 DRIVE/INFEED COMPLETED BOLTED ASSEMBLY

PN Description

1 Take-up Section Assembly	8 • Single Grooved Roller	18 48" Intermediate Section Assy	28 Drive Pulley Guard	38 • Reducer
2 Right Side Take-up Frame	9 • Double Grooved Roller	19 48" Intermediate Frame Side	29 • 1 7/16" 3 Bolt Flange Bearing	39 • Motor
3 Left Side Take-up Frame	10 • Deck Roller Assembly	20 84" Intermediate Section Assy	30 3/8" x 2 1/2" Push Bolt	40 • Driven Sprocket
4 Take-up Pulley Guard	11 Adjustment Bracket	21 84" Intermediate Frame Side	31 • Drive Pulley	41 • Drive Sprocket
5 Spreader Weldment	12 6" Intermediate Section Assembly	22 120" Intermediate Section Assy	32 • Snub Roller/Hex Shaft	42 • Chain
6 • Take-up Pulley	13 6" Intermediate Frame Side	23 120" Intermediate Frame Side	33 Motor Base	43 Manual
7 • Take-up Bearing Assembly	14 12" Intermediate Section Assy	24 Bottom Spreader	34 2 high "Z" Bracket	44 Manual Tube Cap
	15 12" Intermediate Frame Side	25 Drive Section Assembly	35 Guard Back	
	16 24" Intermediate Section Assy	26 Motor Side Drive Frame	36 Guard Weldment	
	17 24" Intermediate Frame Side	27 Non- Motor Side Drive Frame	37 Manual Tube	
				• Recommended spare parts to be stocked at your location