

Replacement Parts List for Model # 802



DRIVE 38
COMPLETED BOLTED ASSEMBLY

INTERMEDIATE
COMPLETED BOLTED ASSEMBLY

INFEED 01
COMPLETED BOLTED ASSEMBLY

17 21 25 26 30 34

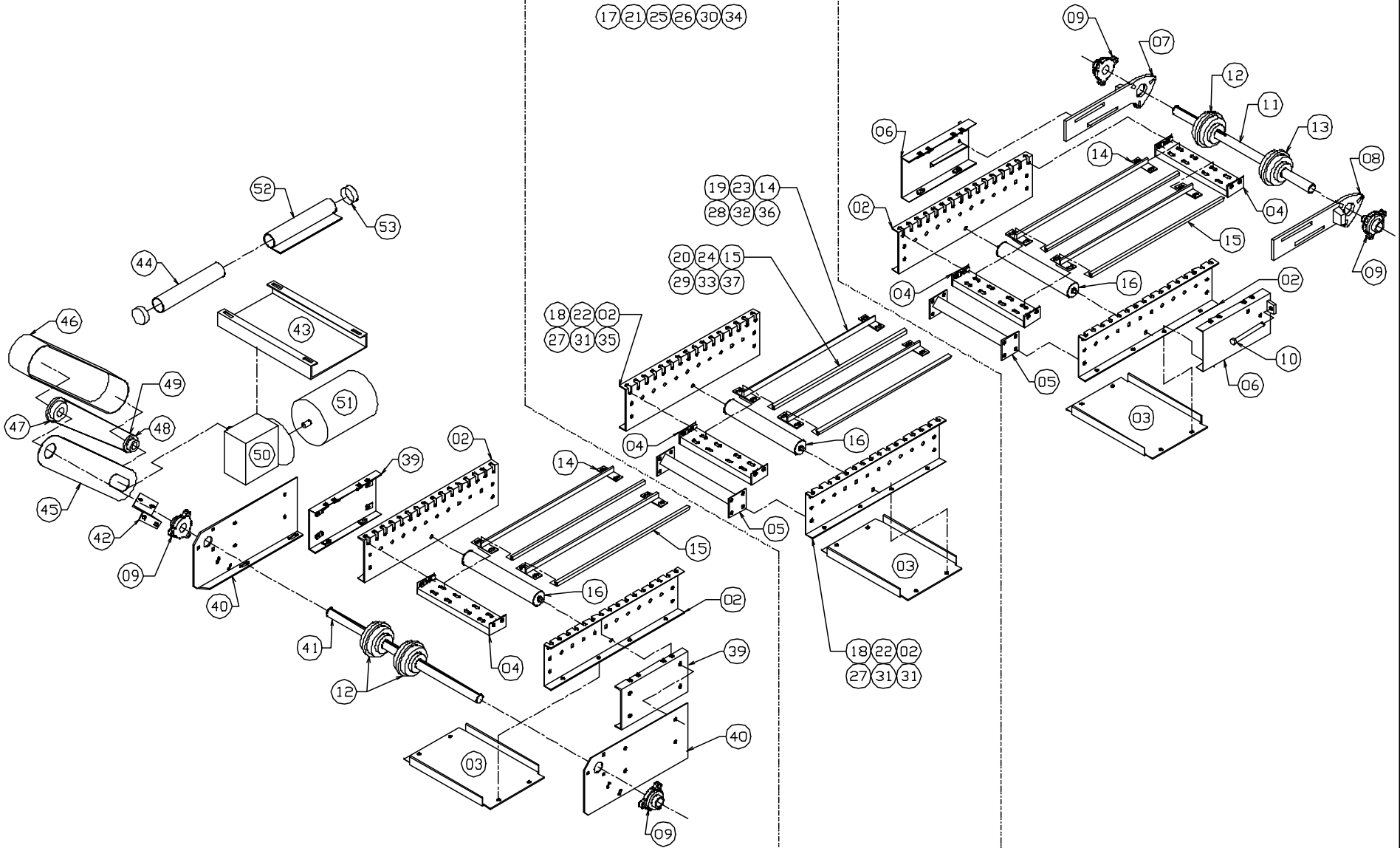

See next page for part numbers and descriptions



Replacement Parts List for Model # 802

PN Description

1 Take-up Section Assembly	28 48" Wearstrip Weldment
2 24" Intermediate Frame Side	29 48" Long Wearstrip
3 Bottom Spreader	30 84" Intermediate Section Assembly
4 Deck Spreader Weldment	31 84" Intermediate Frame Side
5 Spreader Weldment	32 84" Wearstrip Weldment
6 Take-up Pocket Weldment	33 84" Long Wearstrip
7 • Right Hand Take-up Bar	34 120" Intermediate Section Assembly
8 • Left Hand Take-up Bar	35 120" Intermediate Frame Side
9 • 1 3/16" 3 Bolt Flange Bearing	36 120" Wearstrip Weldment
10 • 1/2" x 6" Take-up Bolt	37 120" Long Wearstrip
11 Infeed Shaft	38 Drive Section Assembly
12 Sprockets, Infeed/Drive (Fixed)	39 Drive Plate Mount
13 Sprocket, Infeed (Floater)	40 Drive Plate
14 24" Wearstrip Weldment	41 • Drive Shaft
15 24" Long Wearstrip	42 2" High "Z" Bracket
16 Deck Roller Assembly	43 Motor Base
17 6" Intermediate Section Assembly	44 Manual Tube Weldment
18 6" Intermediate Frame Side	45 Guard Back
19 6" Wearstrip Weldment	46 Guard Weldment
20 6" Long Wearstrip	47 • Drive Sprocket
21 12" Intermediate Section Assembly	48 • Driven Sprocket
22 12" Intermediate Frame Side	49 • Chain
23 12" Wearstrip Weldment	50 • Reducer
24 12" Long Wearstrip	51 • Motor
25 24" Intermediate Section Assembly	52 Manual
26 48" Intermediate Section Assembly	53 Manual Tube Cap
27 48" Intermediate Frame Side	

- **Recommended spare parts to be stocked at your location**