

Replacement Parts List for Model # 250

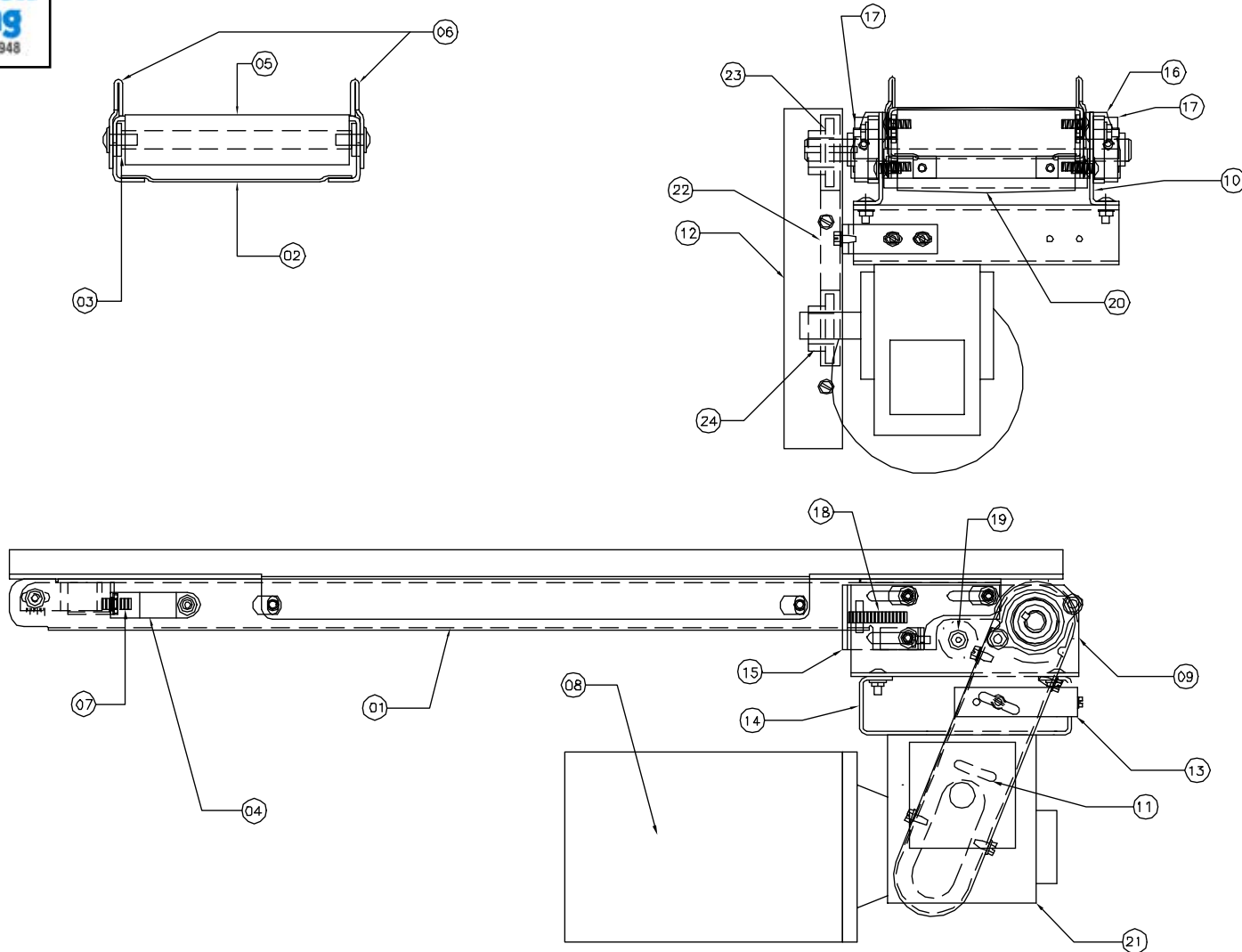

PN Description

01 Frame Weldment	07 Take Up Pusher Bolt (3/8-16 X 1" Full Thread)	13 Guard Mounting Bracket	21 Reducer
02 Bottom Pans	08 Motor	14 Motor Base	22 Drive Chain
03 Infeed Roller Pusher Bracket	09 Head Plate Weldment Right Side	15 Right Side Pusher Bracket	23 Drive Sprocket
04 Access Cover	10 Head Plate Weldment Left Side	16 Left Side Pusher Bracket	24 Driven Sprocket
05 Infeed Roller	11 Guard Back	17 2-bolt - 3/4" Bore Bearing	
06 Siderails	12 Guard Weldment	18 Drive Take Up Pusher Bolt (3/8"-16 X 2")	
		19 Snub Roller	
		20 Drive Pulley	