

Replacement Parts List for Model # 150

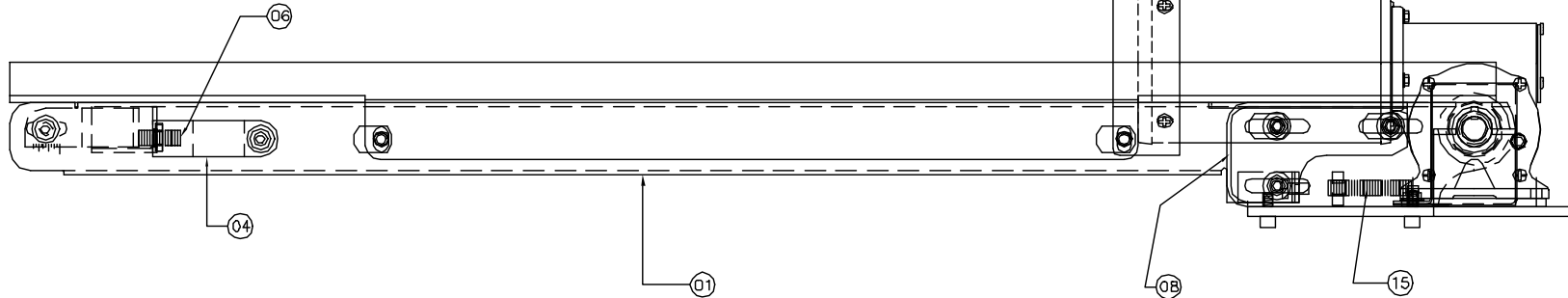
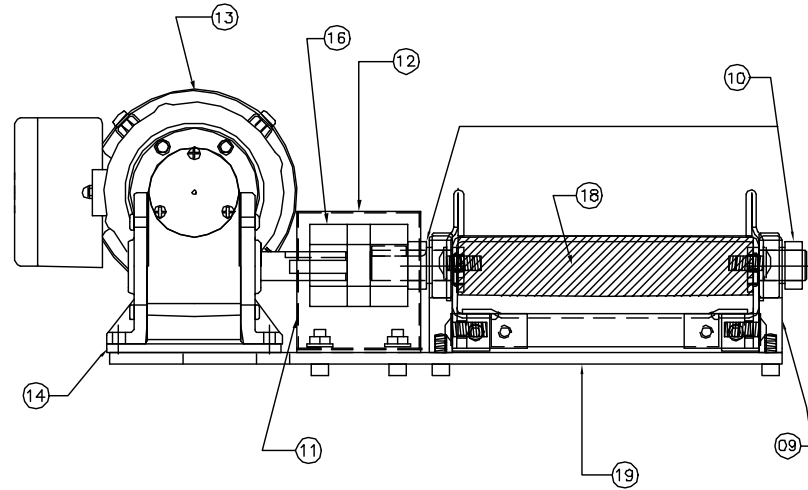
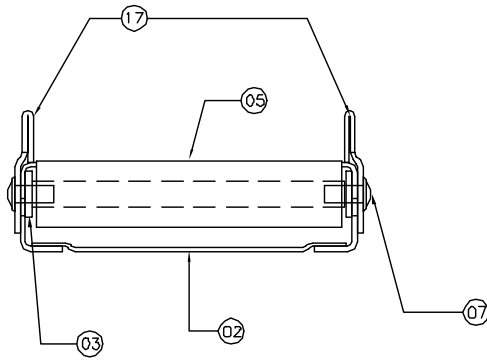

PN Description

01 Frame Weldment	06 Take Up Pusher Bolt (3/8-16 X 1" Full Thread)	11 Bottom Coupler Guard	19 Motor Base
01 Frame Weldment	07 Flanged Screws (5/16"-18 X 3/4")	12 Top Coupler Guard	
02 Bottom Pans	08 Head Plate Weldment Right Side	13 Gearmotor	
03 Infeed Roller Pusher Bracket	09 Head Plate Weldment Left Side	14 Gearmotor Spacer	
04 Access Cover	10 Press In Bearing w/ 5/8" Bore	15 Drive Take Up Pusher Bolt (3/8"-16 X 2")	
05 Infeed Roller	11 Bottom Coupler Guard	16 Shaft Coupler	
	12 Top Coupler Guard	17 Siderails	
	13 Gearmotor	18 Drive Pulley	