

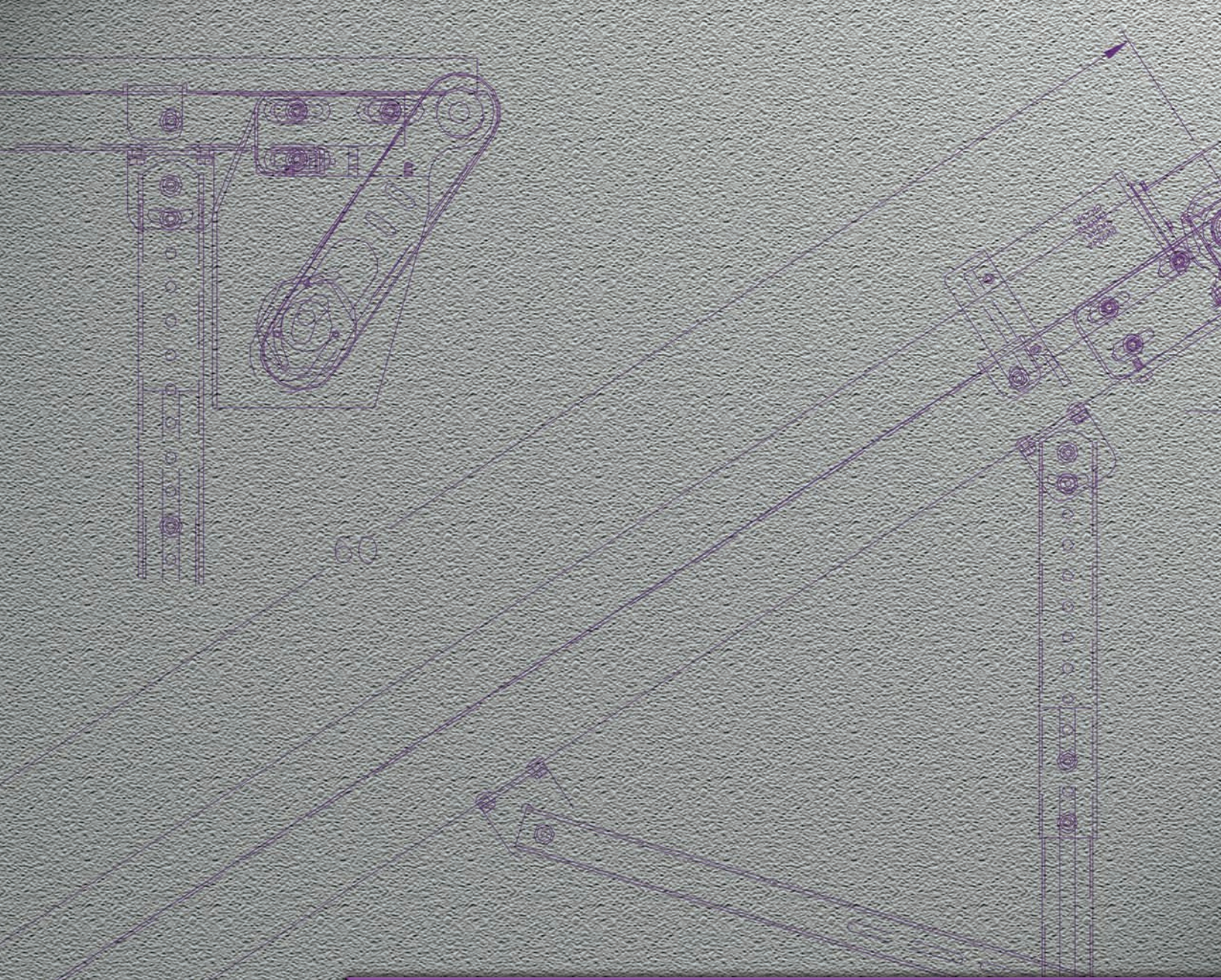









Quality Conveyors Since 1948

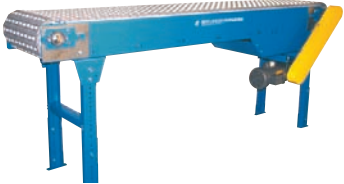

## PlastiTrak – Plastic Belt Conveyors

# PlastiTrak Catalog Table of Contents

Photo	Model	Application	Page
	<b>1000-S</b>	This conveyor is commonly used in bottling operations, dairies and pharmaceutical plants to carry lightweight products like bottles or cans.	<b>2-3</b>
	<b>1000-C</b>	This conveyor is commonly used in bottling operations, dairies and pharmaceutical plants to carry lightweight products thru right hand or left hand curve.	<b>4-5</b>
	<b>2000-S</b>	<b>General Transport Applications</b> – This unit is designed for low cost, general transport applications in light duty production and packaging operations.	<b>6-7</b>
	<b>2000-S</b>	<b>Accumulation Applications</b> – Used for accumulations on product ranging from boxes of candy or laundry detergents accumulations of irregular shaped products like newspapers or magazines.	<b>8-9</b>
	<b>2000-C</b>	Used in production and packaging operations requiring a right hand or left hand curve.	<b>10-11</b>
	<b>2000-CF</b>	Used in applications that require curves and elevation changes.	<b>12-13</b>
	<b>2000-F</b>	This unit uses flights (cleats) to carry small unboxed products like plastic parts, nuts, bolts, plastic bottles, cans or stampings up an incline.	<b>14-15</b>
	<b>2000-N</b>	This unit is designed to carry boxes (packaged items) up an incline or down a decline.	<b>16-17</b>
<b>PlastiTrak Model Summary (a comparison of the Model 1000 and Model 2000)</b>			<b>1</b>
<b>Transfers and Accurate Product Positioning (Case Turning, De-Palletizing, Merging and Transfers)</b>			<b>18</b>
<b>Definition Page</b>			<b>19</b>
<b>Quote Request Form</b>			<b>20</b>
<b>Top Ten Benefits of PlastiTrak</b>			<b>21</b>

# PlastiTrak Model Summary

## Our plastic belt line includes two model classifications:

MODEL	PRODUCT CLASS	COMMENTS
1) Model 1000	Narrow widths, lighter weight products	These units are typically used to convey lighter products like bottles and cans. Since the live loads for these applications are typically lighter, lighter construction features including a 12-gauge frame are standard for this unit. This conveyor is common in bottling operations, dairies and pharmaceutical plants. The Model 1000 chains are also ideal for multiple strand applications.
2) Model 2000	Wider widths, heavier and larger products	These units are typically used to convey larger items like boxes and cases as well as heavier products like stacks of lumber or loaded pallets. This unit's durable construction and design includes a 10-gauge frame capable of handling heavier and larger products.

FEATURE	COMMENTS & BENEFITS	MODEL 1000	MODEL 2000
Frame Gauge	A thicker wall, and deeper frame can support greater live loads and the stress of larger products. A heavier frame is also capable of handling more daily abuse in the manufacturing environment. (There is a lesser probability of structural damage if a forklift were to hit a heavier, walled, deeper frame unit.)	12 ga.	10 ga.
Frame Depth		6-11/16"	7-5/8"
Frame Spreaders	The Model 2000 10 gauge spreaders and the increased strength of a formed channel design provides the durability needed for larger and heavier products with greater live loads.	12 ga. angled	10 ga. formed
Belts	The typical M1000 chains have become more of a commodity priced item and are commonly cheaper per square foot.	Limited to narrow widths	More belt width choices
Frame Widths	The M2000's additional 3/8" overall width doubles the amount of internal clearance on the belt return. More clearance means fewer jam ups resulting in a smoother running, more productive machine.	BW + 1/2"	BW + 7/8"
Shafts	A larger shaft provides increased strength and greater torque capacity. Shaft deflection from smaller shafts may prevent sprockets from engaging properly resulting in "jumping" and jam ups. A square shaft is stronger than conventional round shafts and allows for the higher horsepower needed for heavier loads.	1-3/16" round	1-1/2" square
Return Rollers	A larger roller reduces roller resistance and roller speed resulting in a smoother running and longer lasting conveyor and conveyor parts. Larger return rollers also allow for increased conveyor speeds.	2"	2-1/2"
Wear Strips	The Model 2000 customized wearstrip design and materials will reduce the sliding friction between the belt and frame increasing the useful life of the wear strip and belt.		
ACT System	The Model 2000 includes New London's exclusive ACT System (Application Change Technology). This system provides the end user with the flexibility to exchange the existing belt with another if the application or product changes in the future. The safety and flexibility of this feature has the potential to save the end user thousands of dollars in future conveyor purchases.		See Photo Below

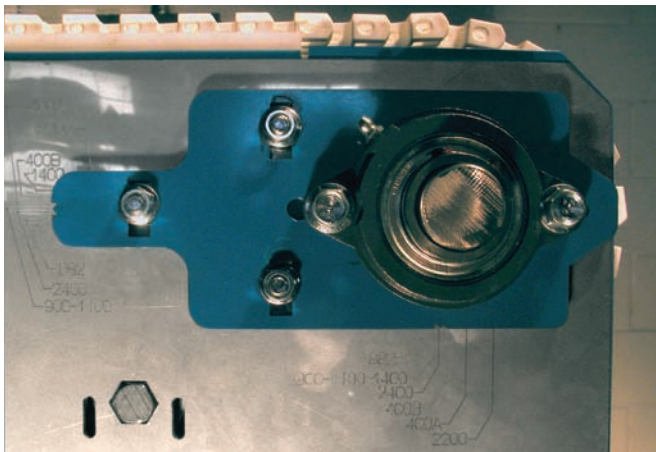

New London's exclusive ACT System (Application Change Technology) provides the end user with the safety and flexibility to exchange the existing belt if the application or product changes. The system is designed to provide the room and clearance for various sprocket and belt styles. All you have to do is loosen the bolts on the shafts "floating" assembly mechanism and then align the arrows to the designated belt number.

# MODEL 1000-S Straight Running Horizontal Plastic Chain Conveyors

(These pages show the Model 1000-S with belts for straight running applications)

**The Model 1000-S (S=Straight Running) is designed for straight running applications. This unit is capable of supporting various styles of plastic chains and metal chains. This conveyor is used to carry lighter weight products common in bottling operations, dairies and pharmaceutical plants.**

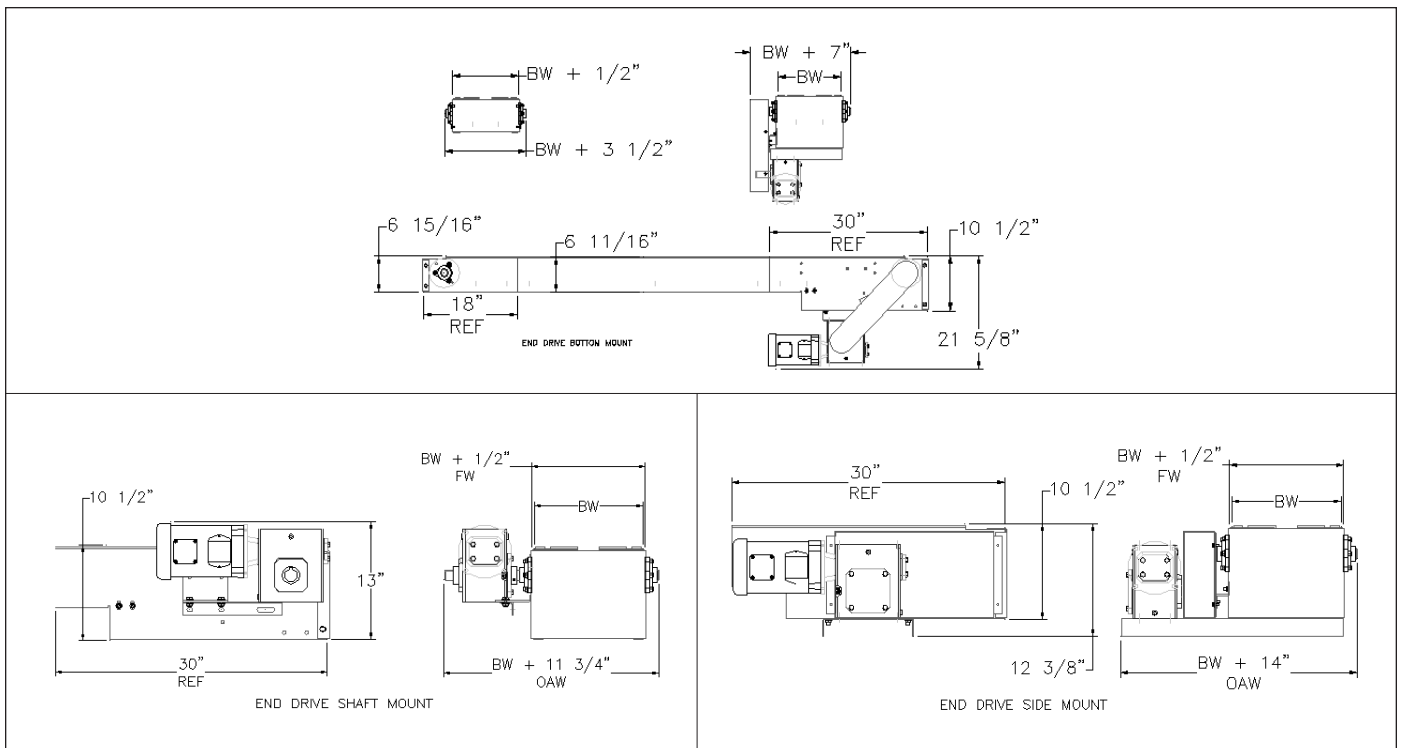
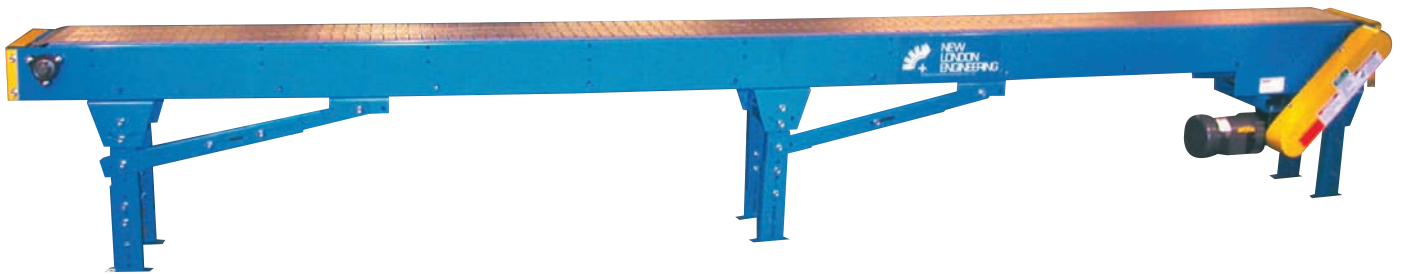

For a larger version of a drawing or to print a copy see our website at [WWW.NLECO.COM](http://WWW.NLECO.COM) and click on DRAWINGS

## Model 1000-S Specifications

**Frame:** 12 Gauge x 6-11/16" Deep

**Frame Width:**  $BW + 1/2"$





**Frame Spreaders:** 12 Gauge Formed Angle

**Shafts:** 1-3/16" Round Shafts

**Return Rollers:** 2" Diameter x 7/16" Hex

**Wear Strips:** Straight Arrangements

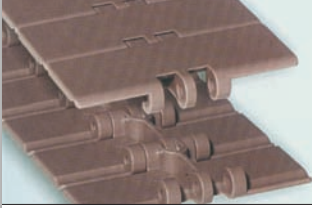
# MODEL 1000-S Straight Running Horizontal Plastic Chain Conveyors

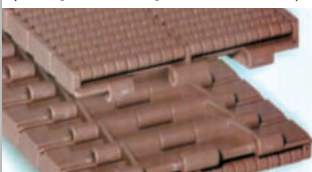
CHAIN NUMBER	APPLICATIONS AND CHAIN QUALITIES
<p>815 Stainless Steel Chain</p> 	<p>This non-magnetic chain has excellent acid, corrosion and abrasion resistance properties. The austenitic stainless steel used in this chain also provides more heat resistance than carbon steel (up to 800 degrees dry vs. carbon steel's 350 degrees). This chain is commonly used to convey products like glass containers, hot metal parts and other parts where water or lubricants are present.</p>
<p>815 Carbon Steel Chain</p> 	<p>This is a strong, abrasion resistant, fine grained, hardened carbon steel chain. This chain is built for applications where the chain is subjected to very abrasive conditions due to the environment or product surfaces. It is used to convey irregularly shaped products such as castings and machined steel parts and other applications that require the high strength and impact resistance of a hardened chain.</p>
<p>820 Plastic Chain</p> 	<p>This low cost, all purpose chain is available in a wide range of chain widths. This chain is the ideal choice for dry, straight running applications. The lightweight qualities of this thin chain also permits use with faster operating speeds.</p>
<p>821 Plastic Chain</p> 	<p>This thicker plastic chain is a bit more expensive than the 820 series but it is capable of handling a wider range of products with higher live loads. All in all, this is still a low cost alternative chain compared to competitors in its class.</p>
<p>LBP 821 Plastic Chain (Straight Running Accumulations)</p> 	<p>This chain uses rollers to reduce friction for accumulation applications. Its small, closely spaced rollers are ideal for accumulating products with a small footprint like bags of snacks and candy as well as irregular shaped items like magazines or newspapers.</p>

## Straight Running Chain Specifications

CHAIN #	MATERIAL	PRICE COMPARED TO M1000 BELTS**	OTHER PRICE COMPARISONS	CHAIN THICKNESS	CHAIN STRENGTH (LBS.)	AVAILABLE CHAIN WIDTHS
815	Stainless Steel	\$\$\$	The 815 carbon steel is about half the price of 815 stainless steel	.12	.625	2-1/4", 2-5/8", 3-1/4", 4, 4-1/4", 6, 7-1/2"
815	Carbon Steel	\$\$		.12	.625	
820	Plastic	\$	The 820 chain is about 20% less expensive than the 821 chain	.16	.365	3-1/4", 4, 4-1/2", 6, 7-1/2"
821	Plastic	\$\$		.19	.625	
LBP821	Plastic	\$\$\$\$\$	The LBP 821 is about 10% more expensive than the LBP 882.	.54	.625	7-1/2", 10, 12"

\*\* See page 19

# MODEL 1000-C Standard Chains for Curved Applications

The Model 1000-C (C=Curved) is used when the application requires right hand or left hand curves. This unit is capable of supporting various styles of plastic and metal chains. This conveyor is used to carry lighter weight products common in bottling operations, dairies and pharmaceutical plants.

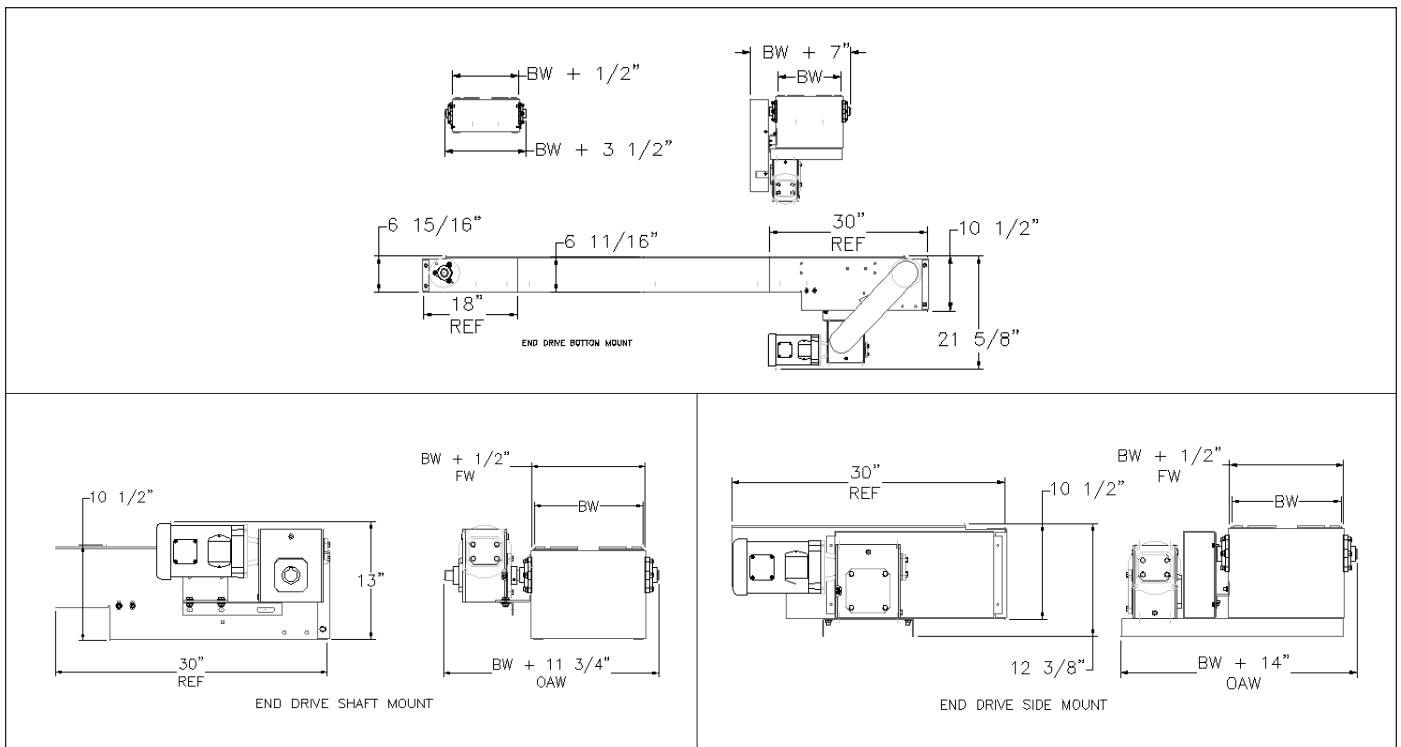

For a larger version of a drawing or to print a copy see our website at [WWW.NLECO.COM](http://WWW.NLECO.COM) and click on DRAWINGS

## Model 1000-C Specifications

**Frame:** 12 Gauge x 6-11/16" Deep

**Frame Width:** BW + 1/2"





**Frame Spreaders:** 12 Gauge Formed Angle

**Shafts:** 1-3/16" Round Shafts

**Return Rollers:** 2" Diameter x 7/16" Hex

**Wear Strips:** Straight Arrangements

# MODEL 1000-C Standard Chains for Curved Applications

CHAIN NUMBER	APPLICATIONS AND CHAIN QUALITIES
<b>LBP 882 Plastic Chain</b> (Curved Accumulations) 	This chain uses rollers to reduce friction for accumulation applications. Its small, closely spaced rollers are ideal for accumulating small products with a small footprint like bags of snacks and candy as well as irregular shaped items like magazines or newspapers.
<b>881 Tab Stainless Steel Chain</b> 	This non-magnetic chain has excellent acid, corrosion and abrasion resistance properties. The austenitic stainless steel used in this chain also provides more heat resistance than carbon steel (up to 800 degrees dry vs. carbon steels 350 degrees). This chain is commonly used to convey products like glass containers, hot metal parts and other parts where water or lubricants are present.
<b>881 Tab Carbon Steel Chain</b> 	This is a strong, abrasion resistant, fine grained, hardened carbon steel chain. This chain is built for applications where the chain is subjected to very abrasive conditions due to the environment or product surfaces. It is used to convey irregularly shaped products such as castings and machined steel parts and other applications that require the high strength and impact resistance of a hardened chain.
<b>882 Tab Plastic Chain</b> 	This low cost, all purpose chain is available in a wide range of chain widths. This chain is the ideal choice for dry, curved applications.
<b>882 Tab Plastic Chain</b> (With Molded Inserts) 	This low cost chain has a high friction insert molded to each plate for use in curved incline/decline applications.

## Curved Chain Specifications

CHAIN #	MATERIAL	PRICE COMPARED TO M1000 BELTS**	OTHER PRICE COMPARISONS	CHAIN THICKNESS	CHAIN STRENGTH (LBS.)	AVAILABLE CHAIN WIDTHS
LBP 882	Plastic	\$\$\$\$\$	The LBP 882 is about 10% cheaper than the LBP 821 straight running chain	.69	.625	7-1/2", 10, 12"
881	Carbon Steel	\$\$\$	The 881 carbon steel is about 20% more economical than 881 stainless steel	.12	.625	3-1/4", 4-1/2", 7-1/2"
881	Stainless Steel	\$\$\$		.12	.625	
882 Tab	Plastic	\$\$\$	NA	.19	.625	3-1/4", 4-1/2", 7-1/2", 10", 12"
882 Tab	Plastic (Molded Inserts)	\$\$\$	NA	.19 + .08 for inserts	.625	7-1/2", 10, 12"

\*\*See page 19

# MODEL 2000-S Straight Running Horizontal Plastic Belt Conveyors

(These pages show the Model 2000-S with general transport very economical belt choices)

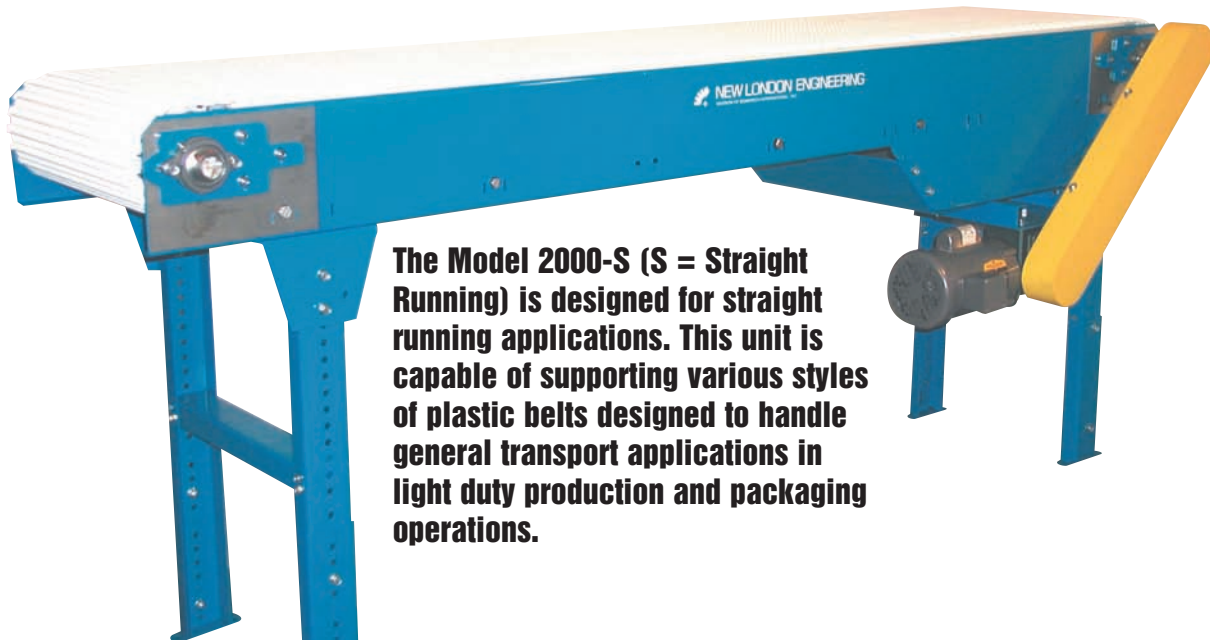

**The Model 2000-S (S = Straight Running) is designed for straight running applications. This unit is capable of supporting various styles of plastic belts designed to handle general transport applications in light duty production and packaging operations.**

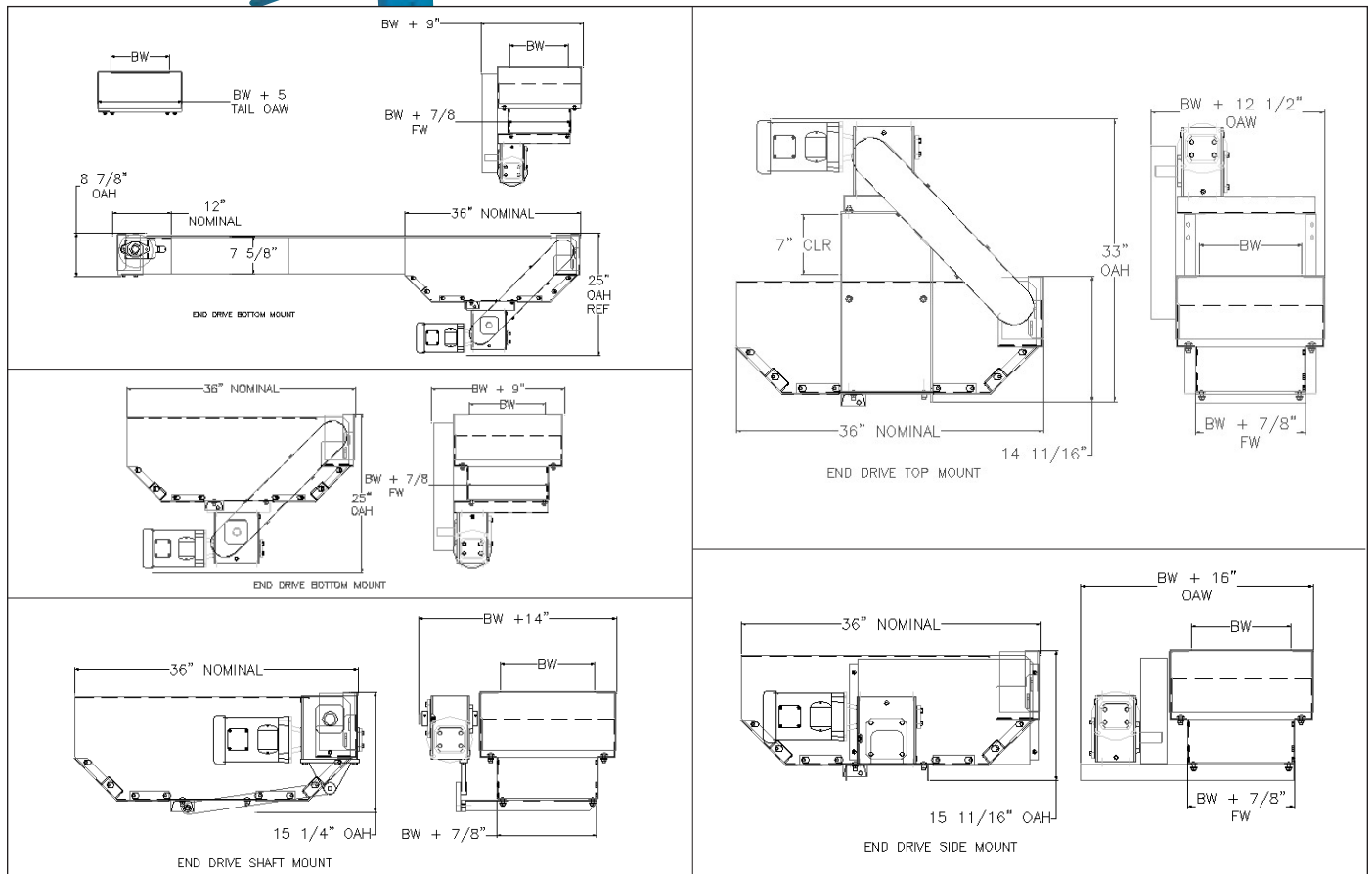

For a larger version of a drawing or to print a copy see our website at [WWW.NLECO.COM](http://WWW.NLECO.COM) and click on **DRAWINGS**

## Model 2000-S Specifications

**Frame:** 10 Gauge x 7-5/8" Deep

**Frame Width:** BW + 7/8"

**Frame Spreaders:** 10 Gauge Formed Channel

**Shafts:** 1-1/2" Square Shafts

**Return Rollers:** 2-1/2" Diameter x 11/16" Hex

**Wear Strips:** Available in Both Straight and Chevron Style Arrangements

**Other:** ACT System (Application Change Technology) see page 1



# MODEL 2000-S Straight Running Horizontal Plastic Belt Conveyors







## General Transport Belt Options

### Model 2000-S

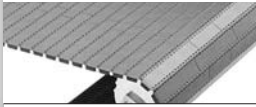
#### Standard Belts for Use in Straight Running General Transport Economical Applications

**Flat Top Belts** – This belt’s smooth, flat and totally closed surface is ideal for conveying small products that may get caught in the open surface of a flush grid. Also used in applications where product tipping or falling may be a problem.

**Flush Grid Belts** – The flush grid open surface is ideal for applications where air flow or liquid drainage are required. Flush grid belts are lighter than flat top belts, which make them more suitable for long, wide conveyor runs. Because there is less surface contacting products, friction is reduced so flush grid belts can also be used for slight accumulation and lateral movement applications. A flush grid belt is **not** recommended when the product is very small or has an uneven surface because these products may get caught in the flush grid belt’s open areas. They are also 3-5% cheaper than flat tops.

INTRALOX BELT SERIES	PRIMARY APPLICATIONS	TYPICAL APPLICATIONS AND PRODUCTS
 900 Flat Top	Ideal for transporting <b>lightweight</b> products over fairly long distances where light impact is possible. The 1.07" pitch facilitates tight conveyor-to-conveyor transfers and produces low chordal action* for smoother operation at higher conveyor speeds.	This low chordal action* belt is ideal for <b>very small and delicate</b> products and where <b>tipping or falling</b> may cause a problem. This belt is ideal for individually filled cans, bottles, plastic containers, light cases, boxes or totes as well as delicate products like glassware and lightly stacked items like reams of paper or napkins.
 900 Flush Grid		
 1400 Flat Top	Used to convey <b>medium to heavy</b> weight products. This thick, strong belt is good for high impact applications and long and wide conveyors. This belt is unique in that it has a small pitch which results in minimal chordal* action, yet it has a robust .5" thickness resulting in an extremely durable belt good for everything from light products with <b>tight transfers to medium to heavy</b> products in <b>high impact</b> applications.	Typical products conveyed on the series <b>1400</b> belt range from <b>medium</b> weight products like individually filled cans, bottles or plastic containers and stacks of paper to <b>heavier</b> products like stacks of lumber or containerboard and loaded shipping pallets and cases.
 1400 Flush Grid		
 400 Flat Top	This <b>extremely thick and strong</b> 2" pitch belt is ideal for <b>heavy duty, high impact</b> applications and <b>exceptionally long, wide conveyor</b> runs carrying heavy products.	Used to convey <b>heavy</b> products like furniture, loaded pallets, appliances, large paper rolls, millwork, heavy batteries and stacks of wallboard.
 400 Flush Grid		

### Belt Specifications (\*) (\*\*) See Definition Page on page 19

INTRALOX BELT SERIES	PRICE COMPARED TO ALL M2000 BELTS**	PRICES COMPARED TO BELTS IN THIS TABLE** (900 – 1400 – 400)	BELT MATERIAL*	BELT PITCH*	BELT THICKNESS
900 Flat Top	\$	\$\$	PP	1.07"	.385"
900 Flush Grid	\$		PP	1.07"	.385"
1400 Flat Top	\$\$	\$\$\$	PP	1.00"	.500"
1400 Flush Grid	\$\$		PP	1.00"	.500"
400 Flat Top	\$\$	\$\$\$\$	PP	2.00"	.625"
400 Flush Grid	\$\$		PP	2.00"	.625"

\*\*See page 19

# MODEL 2000-S Straight Running Horizontal Plastic Belt Conveyors

(These pages show the Model 2000-S with belts for straight running accumulation applications)



**The Model 2000-S (S=Straight Running) is designed for straight running applications. These pages show the various styles of belts designed for accumulations of products ranging from boxes of candy or laundry detergent to accumulations of irregular shaped products like newspapers or magazines.**

This is an end view photo of the 400 Roller Top Accumulation Belt.

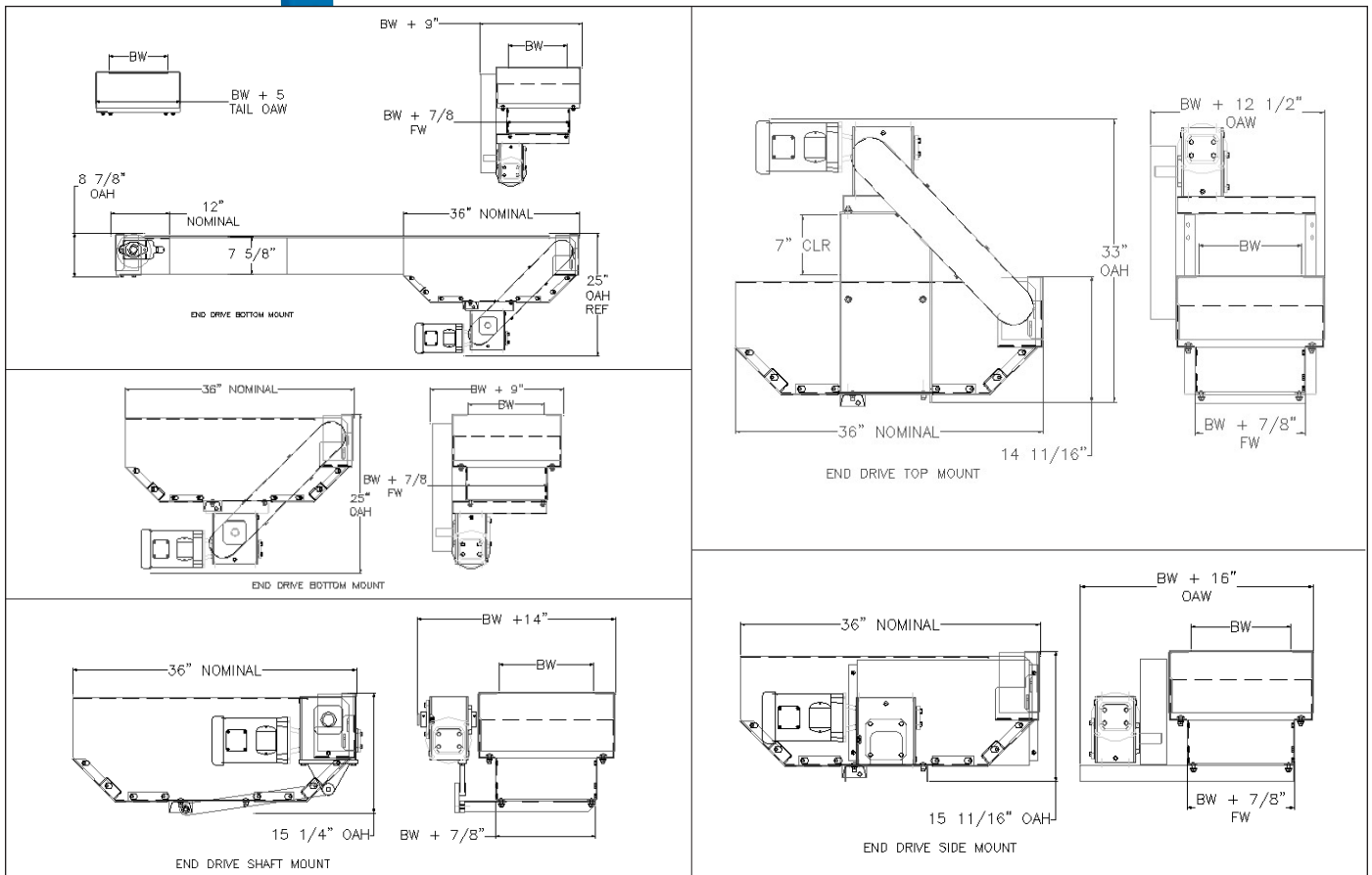

For a larger version of a drawing or to print a copy see our website at [WWW.NLECO.COM](http://WWW.NLECO.COM) and click on DRAWINGS

## Model 2000-S Specifications

**Frame:** 10 Gauge x 7-5/8" Deep

**Frame Width:** BW + 7/8"

**Frame Spreaders:** 10 Gauge Formed Channel

**Shafts:** 1-1/2" Square Shafts

**Return Rollers:** 2-1/2" Diameter x 11/16" Hex

**Wear Strips:** Available in Both Straight and Chevron Style Arrangements

**Other:** ACT System (Application Change Technology) see page 1

# MODEL 2000-S Straight Running Horizontal Plastic Belt Conveyors

## Accumulation Belt Options

### Model 2000-S

#### Standard Belts for Use in Low Back Pressure Accumulation Applications

Note: Because a flush grid belt has less surface contact, friction is reduced so flush grid belts can be used in slight accumulation applications. If back pressure is not a major concern, consider accumulating on a less expensive flush grid belt. (The standard flush grid belts are the series 900, 1400 and 400 shown with the Model 2000-S economical belt choices).

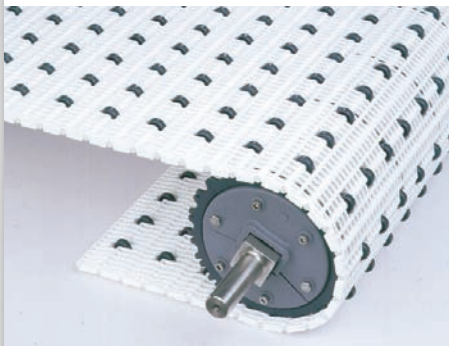
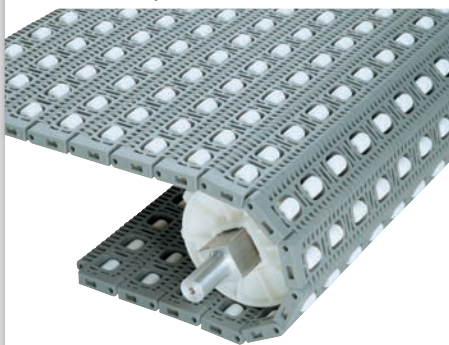
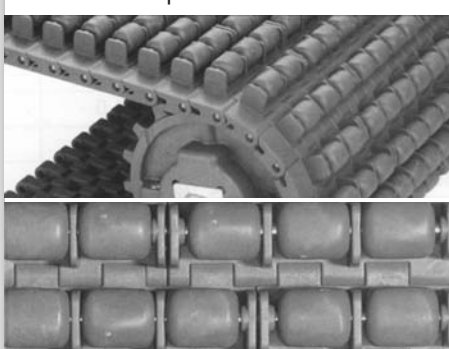
INTRALOX BELT SERIES	PRIMARY APPLICATIONS	TYPICAL APPLICATIONS AND PRODUCTS
<p>900 Roller Top</p> 	<p>This thin, lightweight belt is equipped with narrow light duty rollers which make it ideal for accumulating <b>medium and light weight</b> products. The 1.07" belt pitch facilitates tight conveyor-to-conveyor transfers and produces low chordal action for smoother operation at higher speeds.</p>	<p>Due to its wide roller spacing, this belt works best with products that have <b>flat, rigid bottom surfaces</b>.</p> <p>Ideal for accumulating <b>light to medium weight</b> boxes filled with gum, candy, tissue paper and unfilled cans or plastic bottles.</p>
<p>400 Roller Top</p> 	<p>This thick and extremely strong belt is built with wide, heavy-duty rollers, which makes it ideal for accumulating <b>large and heavy</b> products.</p> <p>This 2" pitch belt has superior pull strength and added beam strength, which makes it ideal for <b>long, wide</b> conveyor runs.</p>	<p>Due to its wide roller spacing, this belt works best with products that have <b>flat, rigid bottom surfaces</b>. Ideal for accumulating <b>heavy</b> cases or boxes containing items such as filled cans, bottles, plastic containers as well as things like laundry detergent, paper products and automotive products.</p>
<p>1400 Roller Top</p> 	<p>This fairly thick and robust belt is made with wide, heavy-duty rollers that are spaced very close together. This narrow spacing increases the amount of product to roller contact making this belt ideal for accumulating <b>irregular shaped and uneven surfaced products as well as small products with fairly small footprints</b>.</p>	<p>Ideal for accumulating bundled products like newspapers and magazines, bags of snacks and candy and all sorts of shrink-wrapped products.</p>

### Roller Top Accumulation Belts – Belt Specifications (\*) (\*\*) See Definition Page on page 19

INTRALOX BELT SERIES	PRICE COMPARED TO M2000 BELTS**	PRICE COMPARED TO BELTS IN THIS TABLE** (900-400-1400)**	BELT MATERIAL	BELT PITCH	BELT THICKNESS	ROLLER SPACING ACROSS WIDTH OF BELT	ROLLER SPACING DOWN LENGTH OF BELT	ROLLER DIAMETER	ROLLER WIDTH
900 Roller Top	\$\$\$\$	\$\$\$	PP*	1.07**	3/8"	2"	1.07"	12/16"	4/16"
400 Roller Top	\$\$\$\$	\$	PP*	2**	5/8"	2"	2"	11/16"	13/16"
1400 Roller Top	\$\$\$\$	\$\$\$\$	A*	1**	4/8"	1"	1"	11/16"	13/16"

\*\*See page 19

# MODEL 2000-C Curved Plastic Belt Conveyors

The Model 2000-C (C = Curved) is used in applications that require right hand or left hand curves.

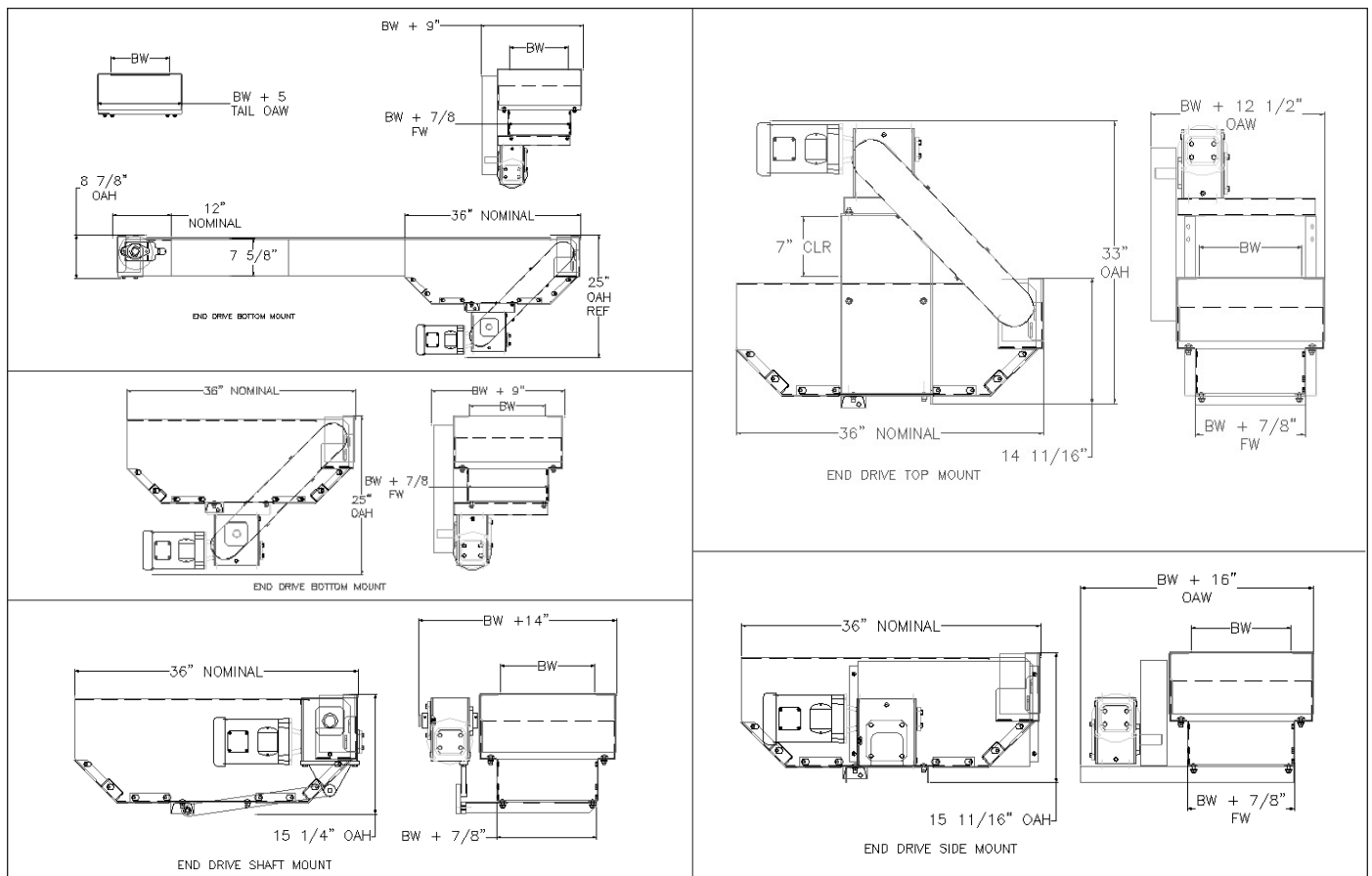

For a larger version of a drawing or to print a copy see our website at [WWW.NLECO.COM](http://WWW.NLECO.COM) and click on DRAWINGS

## Model 2000-C Specifications

**Frame:** 10 Gauge x 7-5/8" Deep

**Frame Width:**  $BW + 7/8"$

**Frame Spreaders:** 10 Gauge Formed Channel

**Shafts:** 1-1/2" Square Shafts

**Return Rollers:** 2-1/2" Diameter x 11/16" Hex



**Wear Strips:** Available in Both Straight and Chevron Style Arrangements

**Other:** ACT System (Application Change Technology) see page 1

# MODEL 2000-C Curved Plastic Belt Conveyors

## Model 2000-C Belts for Curved Applications

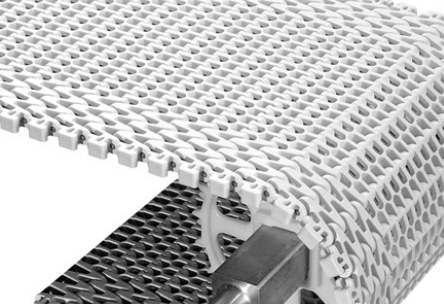
**Flush Grid Belts** – The flush grid belt’s open surface makes them ideal for use in applications where air flow and drainage are required. Because there is less surface contacting products, there is less friction, so flush grid belts can also be used for slight accumulation and lateral movement applications. A flush grid belt is **not** recommended when the product is very small or has an uneven surface because these products may get caught in the flush grid belt’s open space.

INTRALOX BELT SERIES	PRIMARY APPLICATIONS	TYPICAL APPLICATIONS AND PRODUCTS
<p>2400 Flush Grid</p> 	<p>Used in <b>light to medium</b> duty curved or side flexing applications. This belt is available in both a 2.2 turning radius and 1.7 tight turning radius***.</p> <p>The small 1" pitch design facilitates tight conveyor-to-conveyor transfers especially for small delicate products.</p>	<p>This belt’s low chordal action* and smooth operation is ideal for conveying all sorts of lightweight packaged products like candy or bakery and boxes filled with light products like napkins or toilet paper. It is also ideal for short stacks of paper and tubs filled with empty plastic containers.</p>
<p>2200 Flush Grid</p> 	<p>Used in <b>medium to heavy</b> duty curved or side flexing applications.</p> <p>This strong 1.5" pitch belt is exceptionally durable and robust belt is ideal for conveying <b>heavy products</b>. Available in 2.2 turning radius*** only.</p>	<p>Used to convey all sorts of boxes filled with heavier products like filled cans, plastic containers, bottles and jars. This belt can also be used to carry larger/taller stacks of paper, cardboard or containerboard and filled pallets.</p>

### Belt Specifications (\*) (\*\*) See Definition Page on page 19

INTRALOX BELT SERIES	PRICE COMPARED TO ALL M2000 BELTS**	PRICES COMPARED TO BELTS IN THIS TABLE**	BELT MATERIAL	BELT PITCH	TURNING RADIUS
2400 Flush Grid	\$\$	\$	PP*	1"**	1.7 & 2.2
2200 Flush Grid	\$\$	\$	PP*	1.5**	2.2

\*\*\*The turning radius is the minimum radius required for the belt to make the turn. It is calculated by multiplying the belts rated turning radius by its width. For example, a 24" wide Series 2200 x 2.2 Turning Radius belt requires a minimum inside turning radius (measured from edge of conveyor) of 52.8 inches (24 x 2.2 = 52.8 inches).

### Common Belt Options:

**Sanoprene Friction Surfaces & Flights:** A sanoprene molded rubber surface or a flight can be attached to the belt to prevent slippery (wet or oily) products from sliding off the belt while traveling through the curve. (Similar to friction top – see M2000-N).

**Sideguards:** Sideguards are used to prevent product from slipping off the belt while traveling through the curve area. Standard sideguards can also be used when products must be separated while being transported.

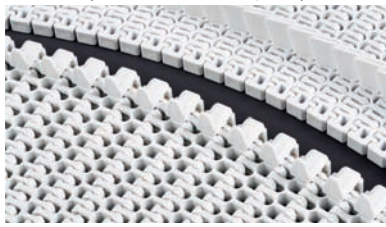
BELT	UNIVERSAL SIDEGUARDS	CLIP-ON SIDEGUARDS
<p>Series 2200 &amp; Series 2400 Flush Grid</p> <p>1 &amp; 3" high sideguards are available</p> <p>A 2.2 turning radius belt requires a 1.5" indent. The 1.7 turning radius belt requires a 3.0" indent.</p>		<p>.75" high clip on sideguards (Available with the series 2400 belt only)</p> <p>The required indent for a clip on sideguard is .6" compared to 1.5" – 3" for a universal sideguard. This feature allows for more of the belt surface to be used for product conveyance.</p>  <p>(Shown in bottom of photo)</p>

# MODEL 2000-CF Curved and Flighted Conveyors (Both a curve and elevation change)

The Model 2000-CF (C = Curved and F = Flighted) is used in applications that require curves and elevation changes.



Front View

Side View



## See Model 2000-C Drawings

For a larger version of a drawing or to print a copy see our website at [WWW.NLECO.COM](http://WWW.NLECO.COM) and click on DRAWINGS

### Model 2000-CF Specifications

**Frame:** 10 Gauge x 7-5/8" Deep (Flights up to 1" High Will Fit in the Standard 7-5/8" Deep Frame)

**Frame Width:** BW + 7/8"

**Frame Spreaders:** 10 Gauge Formed Channel

**Shafts:** 1-1/2" Square Shafts

**Return Rollers:** 2-1/2" Diameter x 11/16" Hex

**Wear Strips\*:** Available in Both Straight and Chevron Style Arrangements

**Other:** ACT System (Application Change Technology) see page 1

BELT SERIES	FRAME DEPTHS (FRAME DEPTH = FLIGHT HT. + 7-5/8" LESS 1")					
2200	Flight Height	1"	2"	3"	4"	The minimum cleat indent is 5/8" per side. Note: Sideguards are not available in the Series 2200 belt. This belt is available in a 2.2 turning radius only.
	Frame Depth	7-5/8"	8-5/8"	9-5/8"	10-5/8"	
2400	Flight Height	1"	2"	3"	<b>Minimum Cleat Indent</b>	<b>Minimum Sideguard Indent</b>
	Frame Depth	7-5/8"	8-5/8"	9-5/8"	Minimum cleat indent is 1-1/8" per side	1.7 turning radius = 3" indent / side 2.2 turning radius = 1.5" indent / side Clip on sideguards = .6" indent / side

# MODEL 2000-CF Curved and Flighted Conveyors (Both a curve and elevation change)

## Model 2000-CF

### Belts for Curved and Flighted Applications – (curve and elevation change units)

**Flush Grid Belts** – The flush grid belt’s open surface makes them ideal for use in applications where air flow and/or liquid drainage are required. With less surface contacting products, there is less friction so flush grid belts can also be used for slight accumulation and lateral movement applications. A flush grid belt is **not** recommended when the product is very small or has an uneven surface because these products may get caught in the flush grid belt’s open areas.

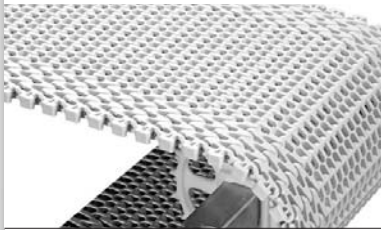
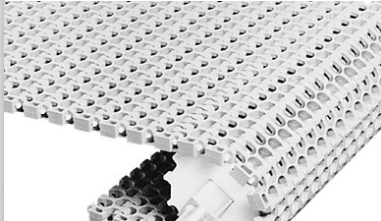
INTRALOX BELT SERIES	PRIMARY APPLICATIONS	TYPICAL APPLICATIONS AND PRODUCTS
<p>2400 Flush Grid</p> 	<p>Used in <b>light to medium duty</b> curved or side flexing applications. This belt is available in both a 2.2 turning radius and 1.7 tight turning radius***.</p> <p>The small 1" pitch design facilitates tight conveyor-to-conveyor transfers especially for small delicate products.</p>	<p>This belt’s low chordal action* and smooth operation is ideal for conveying all sorts of lightweight packaged products like candy or bakery and boxes filled with light products like napkins or toilet paper. It is also ideal for short stacks of paper and tubs filled with empty plastic containers.</p>
<p>2200 Flush Grid</p> 	<p>Used in <b>medium to heavy duty</b> curved or side flexing applications.</p> <p>This strong 1.5" pitch belt is exceptionally durable and robust and is ideal for conveying <b>heavy products</b>. Available in 2.2 turning radius*** only.</p>	<p>Used to convey all sorts of boxes filled with heavier products like filled cans, plastic containers, bottles and jars. This belt can also be used to carry larger/taller stacks of paper, cardboard or containerboard and filled pallets.</p>



### Belt Specifications (\*) (\*\*) See Definition Page on page 19

INTRALOX BELT SERIES	PRICE COMPARED TO ALL M2000 BELTS**	PRICES COMPARED TO BELTS IN THIS TABLE**	BELT MATERIAL	BELT PITCH	TURNING RADIUS
2400 Flush Grid	\$\$	\$	PP*	1**	1.7 & 2.2
2200 Flush Grid	\$\$	\$	PP*	1.5**	2.2

\*\*\* The turning radius is the minimum radius required for the belt to make the turn. It is calculated by multiplying the belts rated turning radius by its width. For example, a 24" wide Series 2200 x 2.2 Turning Radius belt requires a minimum inside turning radius (measured from edge of conveyor) of 52.8 inches. (24 x 2.2 = 52.8 inches)

### Common Belt Options:

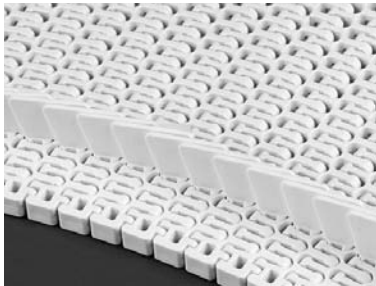
**Sideguards:** Sideguards are used to prevent product from slipping off the belt while traveling through a curve or up an incline. Standard sideguards can also be used when products must be separated while being transported.

BELT	FLIGHTS	UNIVERSAL SIDEGUARDS	CLIP-ON SIDEGUARDS
<p>Series 2400 Flush Grid</p> 	<p>1", 2" &amp; 3" high plastic-ribbed on both sides</p>	<p>1" &amp; 3" high sideguards are available</p> 	<p>.75" high . (Available with the series 2400 belt only) (Shown in bottom of photo)</p> 
<p>Series 2200 Flush Grid</p> 	<p>1", 2", 3" &amp; 4" high plastic – smooth on both sides (4" flight shown)</p>	<p>A 2.2 turning radius belt requires a 1.5" indent. The 1.7 turning radius belt requires a 3.0" indent.</p>	<p>The required indent for a clip on sideguard is .6" compared to 1.5" – 3" for a universal sideguard. This feature allows for more of the belt surface to be used for product conveyance.</p>

# MODEL 2000-F Flighted Plastic Belt Conveyors

The Model 2000-F (F = Flights) is designed to carry small, unboxed, loose products like plastic parts, nuts, bolts, plastic bottles, cans and stampings.

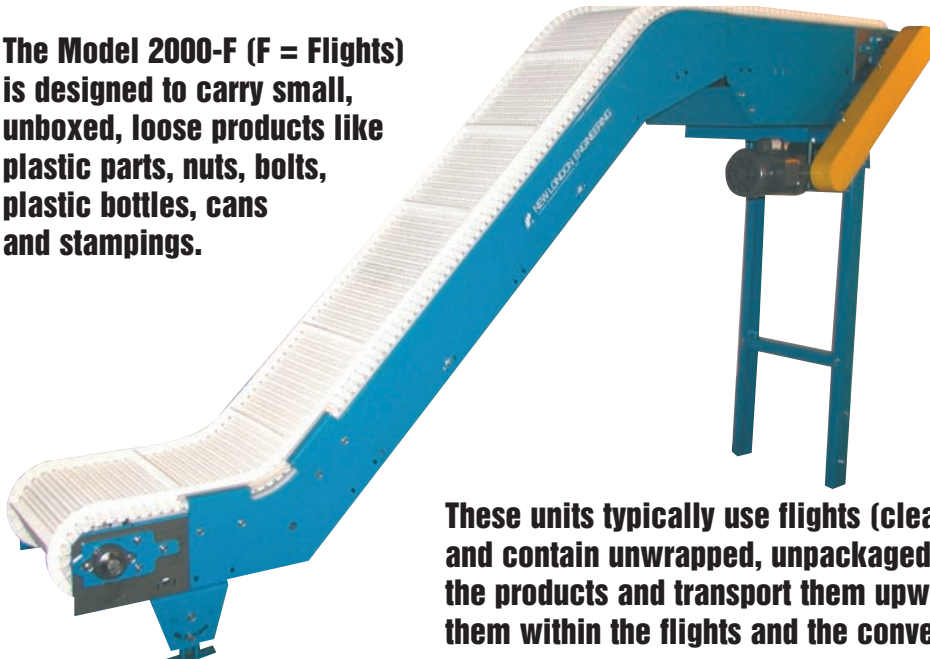

This is a photo of the hold down shoes at the lower curve.

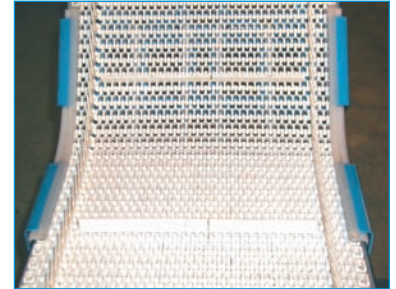

These units typically use flights (cleats) and sideguards to catch, carry and contain unwrapped, unpackaged items. The flights catch and carry the products and transport them upwards while the sideguards contain them within the flights and the conveyor sides.

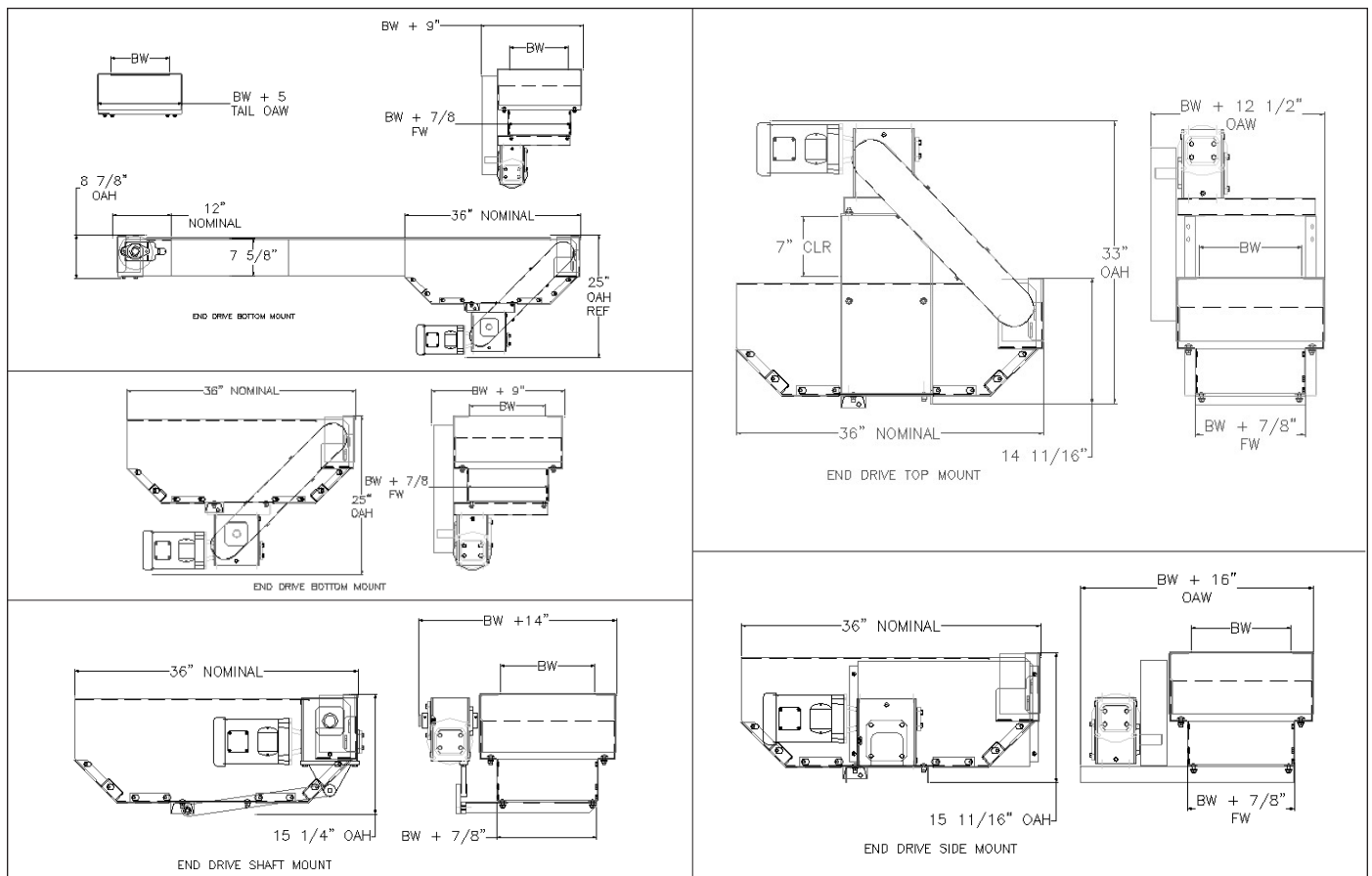

For a larger version of a drawing or to print a copy see our website at [WWW.NLECO.COM](http://WWW.NLECO.COM) and click on DRAWINGS

## Model 2000-F Specifications

**Frame:** 10 Gauge x 7-5/8" Deep (Flights up to 1" high will fit in the standard 7-5/8" deep frame)

**Frame Width:** BW + 7/8"

**Frame Spreaders:** 10 Gauge Formed Channel

**Shafts:** 1-1/2" Square Shafts

**Return Rollers:** 2-1/2" Diameter x 11/16" Hex

**Wear Strips\*:** Available in Both Straight and Chevron Style Arrangements

**Other:** ACT System (Application Change Technology) see page 1







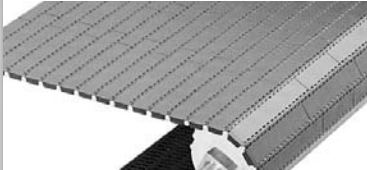
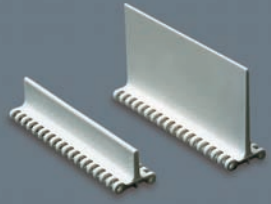
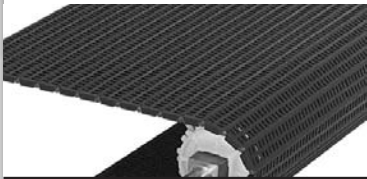

# MODEL 2000-F Flighted Plastic Belt Conveyors

## Model 2000-F Standard Flighted Plastic Belts

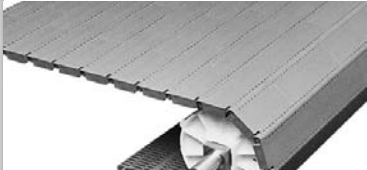
**Flat Top Belts** – This belt’s smooth, flat and totally closed surface is ideal for conveying small products that may get caught in the open surface of a flush grid. They are also used in applications where product tipping or falling may cause a problem.

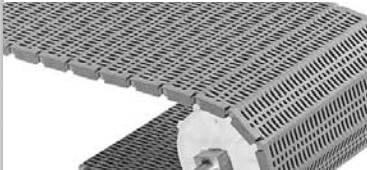
**Flush Grid Belts** – The flush grid belt’s open surface makes them ideal for use in applications where air flow and/or liquid drainage are required. Flush grid belts are lighter than flat top belts, which makes them more suitable for long, wide conveyor runs. With less surface contacting products, friction is reduced so flush grid belts can also be used for slight accumulation and lateral movement applications. A flush grid belt is **not** recommended when the product is very small or has an uneven surface because these products may get caught in the flush grid belt’s open areas. They are also 3-5% cheaper than flat tops.

INTRALOX BELT SERIES	BELT APPLICATIONS	OPTIONS
900 Flat Top 	The series 900 belt is ideal for <b>low impact</b> applications and for transporting <b>small lightweight</b> products like plastic bottles and bottle caps and small screws, nuts, bolts or washers. This lightweight 1" pitch belt facilitates tight transfers and produces low chordal action* for smoother operation at higher conveyor speeds.	Flights – Available in 1, 2, 3" high flights  (1" & 3" flights shown) 
900 Flush Grid 		Sideguards*** Available in 2" high sideguards only 
400 Flat Top 	The series 400 is ideal for <b>high impact</b> applications and for transporting <b>heavier</b> products like scrap metal, slugs or filled cans or plastic bottles. This <b>thick 2" pitch</b> belt has superior pull strength and added beam strength, making it ideal for <b>exceptionally long and wide</b> conveyor runs.	Flights – Available in 1, 2, 3, 4, 6" high flights (1", 2" & 3" flights shown) 
400 Flush Grid 		Sideguards**** Available in 2, 3, 4" high sideguards 

### Belt Specifications (\*) (\*\*) (\*\*\*) See Definition Page on page 19

INTRALOX BELT SERIES	PRICE COMPARED TO M2000 BELTS**	PRICES COMPARED TO BELTS IN THIS TABLE** (900 vs. 400)	BELT MATERIAL*	BELT PITCH*	BELT THICKNESS
900 Cleated Flat Top	\$	\$	PP	1.07"	.385"
900 Cleated Flush Grid	\$				
400 Cleated Flat Top	\$	\$\$	PP	2.00"	.625"
400 Cleated Flush Grid	\$				

\*\*\* The smaller the product the larger the sprocket should be used. When going around the 6, 9, and 10 tooth sprockets, the sideguards will fan out, opening a gap at the top of the sideguard which might allow small products to fall out. The sideguards stay completely closed when wrapping around the 12 tooth and larger sprockets.

\*\*\*\*The smaller the product the larger sprocket should be used. When going around the 6 and 8 tooth sprockets, the sideguards will fan out, opening a gap at the top of the sideguard, which might allow small products to fall out. The sideguards stay completely closed when wrapping around the 10, 12, and 16 tooth sprockets.

# MODEL 2000-N Nose Over Conveyors – Designed to Carry Products From Floor to Floor

The Model 2000-N (N = Nose Over) is designed to carry boxes (packaged items) up inclines or down declines. These units use a belt with a friction top surface rather than a cleat to move products. The Nose Over provides a smooth transition from the incline to the horizontal. Units should not exceed 30-degree inclines.

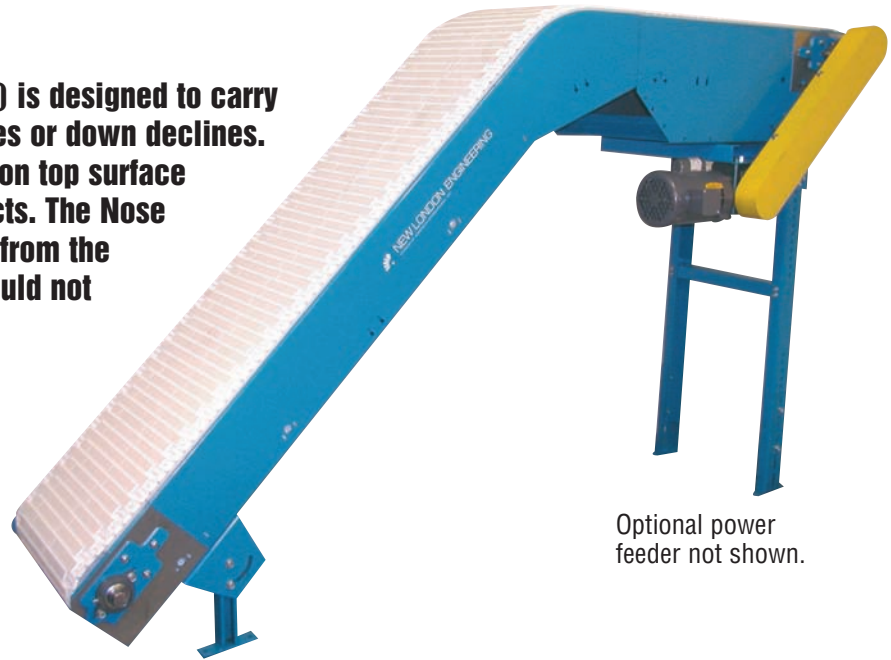

Optional power feeder not shown.

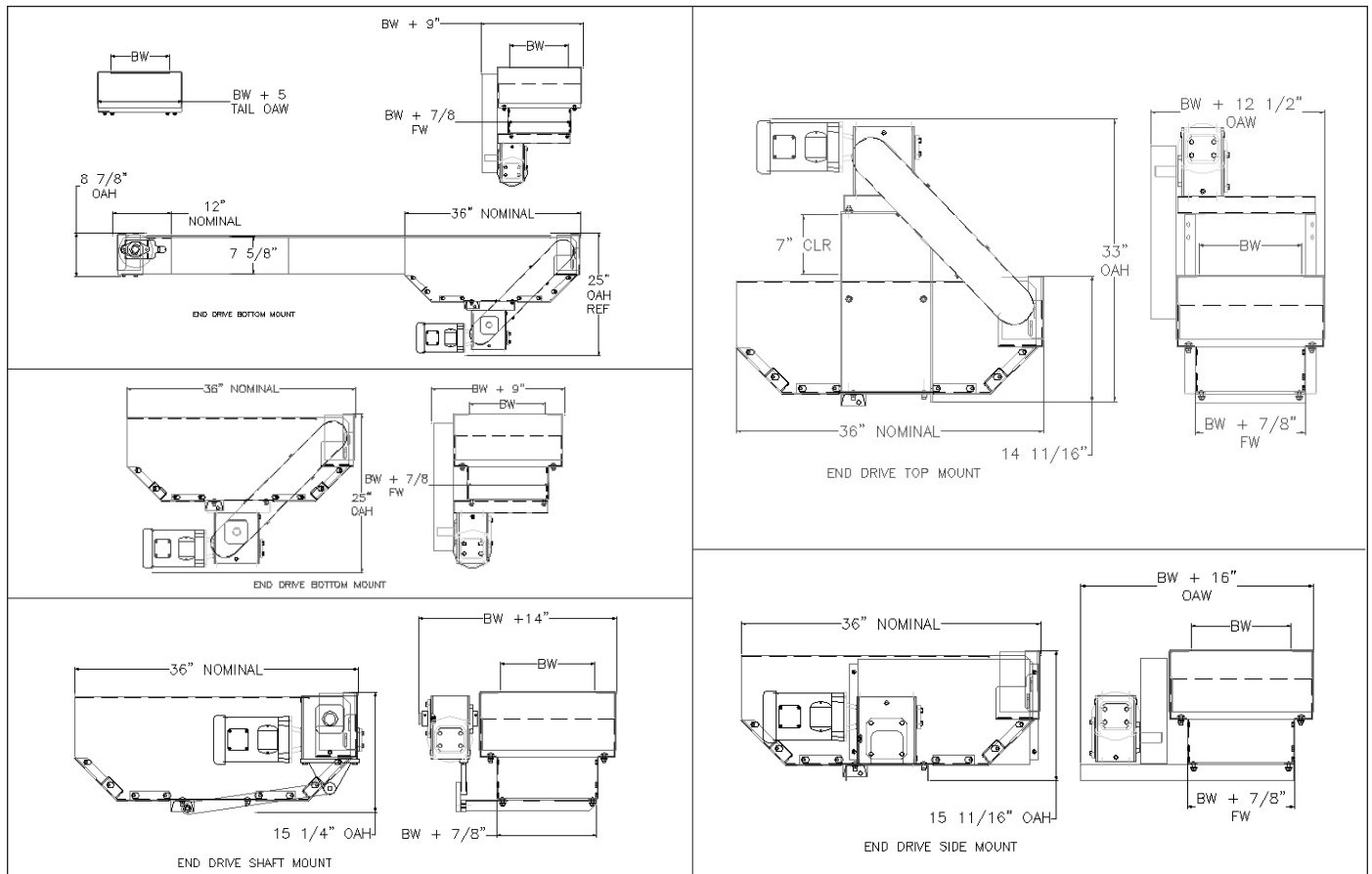

For a larger version of a drawing or to print a copy see our website at [WWW.NLECO.COM](http://WWW.NLECO.COM) and click on DRAWINGS

## Model 2000-N Specifications

**Frame:** 10 Gauge x 7-5/8" Deep

**Frame Width:** BW + 7/8"

**Frame Spreaders:** 10 Gauge Formed Channel

**Shafts:** 1-1/2" Square Shafts

**Return Rollers:** 2-1/2" Diameter x 11/16" Hex

**Wear Strips:** Available in Both Straight and Chevron Style Arrangements

**Other:** ACT System (Application Change Technology) see page 1

# MODEL 2000-N Nose Over Conveyors – Designed to Carry Products From Floor to Floor



## Model 2000-N Standard Belts Used for Floor to Floor Applications

Rubber modules are molded to the surface of the base belt providing a high friction surface for incline and decline applications.

**Flat Friction Top** – The flat friction top is used for standard incline/decline applications.

**Square Friction Top** – The square friction top pattern provides improved product grip for use with larger and heavier products and in steeper incline/decline applications. This option does not clog up with product debris as easily as the flat friction top.

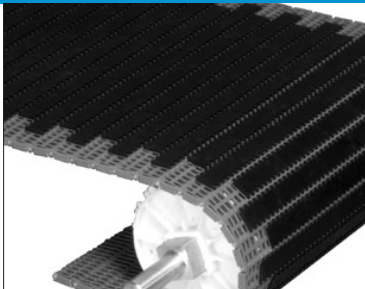
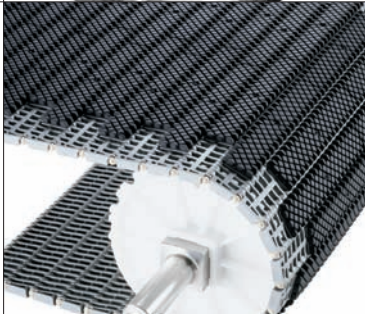
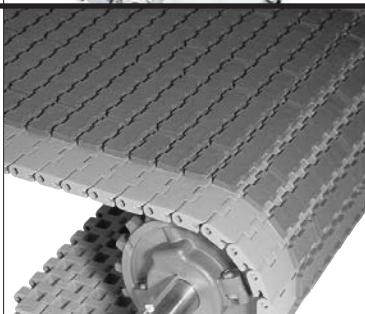
**These friction top belts are a longer lasting alternative to traditional rubber or PVC style rough top slider bed belts.**

INTRALOX BELT SERIES		PRIMARY APPLICATIONS	TYPICAL PRODUCTS
<p>900 Flat Friction Top</p>  <p>Designed for use in standard incline / decline applications</p>	<p>Used in <b>light to medium</b> duty incline / decline applications.</p> <p>This belt's low chordal action* and smooth, flat surface makes it the ideal belt to carry boxes filled with small <b>and delicate products</b> and in applications where product <b>tipping or falling</b> may cause a problem.</p>	<p>The series 900 belt is made to convey <b>light to medium</b> weight cases, boxes, totes and all sorts of lightweight packaged products.</p>	
<p>900 Square Friction Top</p>  <p>Designed for use with larger and heavier products and for steeper incline/decline applications.</p>	<p>Used in <b>medium to heavy</b> duty and <b>high impact</b> incline/decline applications.</p> <p>Extremely <b>durable</b> and <b>robust</b> design provides excellent belt and sprocket durability and longer belt life.</p> <p>This thick 1" pitch belt has superior pull strength and added beam strength making it a better choice for exceptionally long and wide conveyor runs.</p>	<p>The series 1400 belt is the ideal choice for <b>heavier</b> cases, boxes, totes, small pallets and all sorts of packaged products.</p>	
<p>1400 Flat Friction Top</p>  <p>Designed for use in standard incline / decline applications.</p>	<p>Used in <b>medium to heavy</b> duty and <b>high impact</b> incline/decline applications.</p> <p>Extremely <b>durable</b> and <b>robust</b> design provides excellent belt and sprocket durability and longer belt life.</p> <p>This thick 1" pitch belt has superior pull strength and added beam strength making it a better choice for exceptionally long and wide conveyor runs.</p>	<p>The series 1400 belt is the ideal choice for <b>heavier</b> cases, boxes, totes, small pallets and all sorts of packaged products.</p>	
<p>1400 Square Friction Top</p>  <p>Designed for use with larger and heavier products and for steeper incline / decline applications</p>	<p>Used in <b>medium to heavy</b> duty and <b>high impact</b> incline/decline applications.</p> <p>Extremely <b>durable</b> and <b>robust</b> design provides excellent belt and sprocket durability and longer belt life.</p> <p>This thick 1" pitch belt has superior pull strength and added beam strength making it a better choice for exceptionally long and wide conveyor runs.</p>	<p>The series 1400 belt is the ideal choice for <b>heavier</b> cases, boxes, totes, small pallets and all sorts of packaged products.</p>	

### Belt Specifications (\*) (\*\*) See Definition Page on page 19

INTRALOX BELT SERIES	PRICE COMPARED TO ALL MODEL 2000 BELTS**	PRICES COMPARED TO BELTS IN THIS TABLE (900 vs. 1400)**	BELT MATERIAL	BELT PITCH	BELT THICKNESS
900 Friction & Square Top	\$	\$	PP*	1.07**	.570"
1400 Friction & Square Top	\$\$	\$\$\$	PP*	1**	.700"

# TRANSFERS and Accurate Product Positioning Applications

## Case Turning

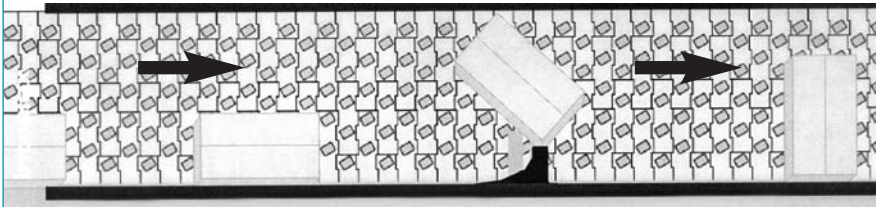

The angled rollers direct the boxes to the edge of the conveyor. The boxes then turn as they hit the case turner.

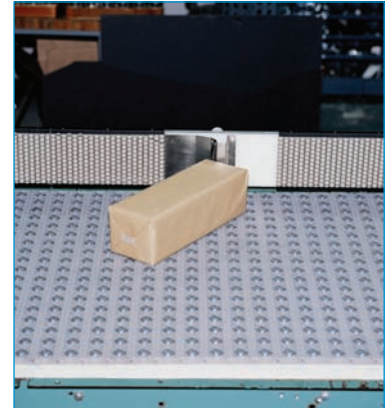

## Merging

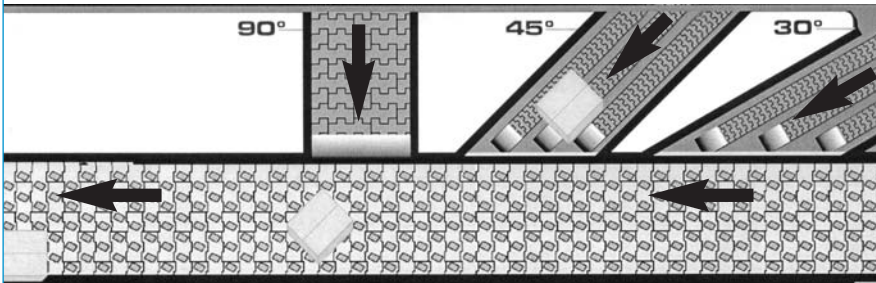

This system properly merges and orients packages of a variety of sizes and shapes, accommodating several infeed lanes from a variety of merge angles. The spinning rollers direct the products to the conveyor edge.

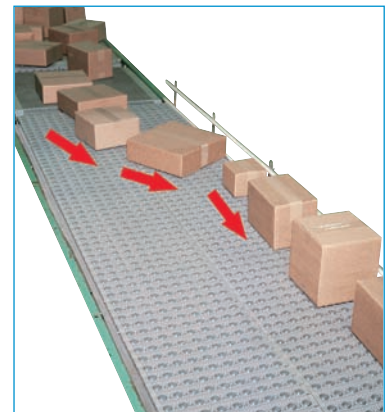

## Depalletizing

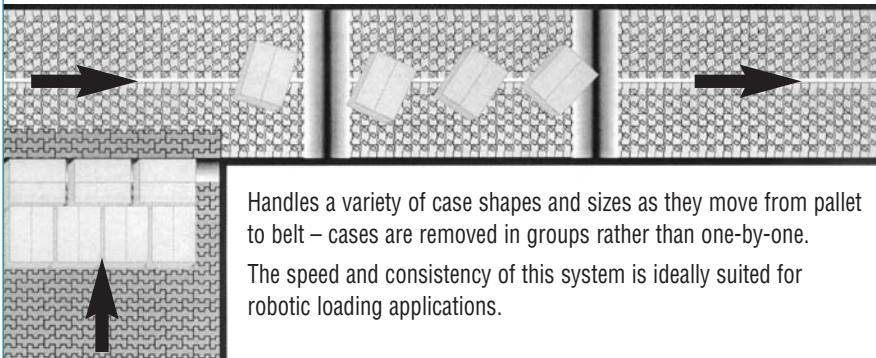

Handles a variety of case shapes and sizes as they move from pallet to belt – cases are removed in groups rather than one-by-one. The speed and consistency of this system is ideally suited for robotic loading applications.

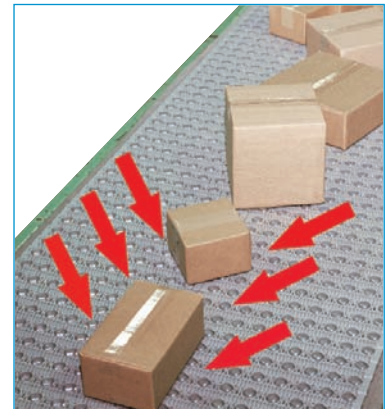

## Center Line Merge

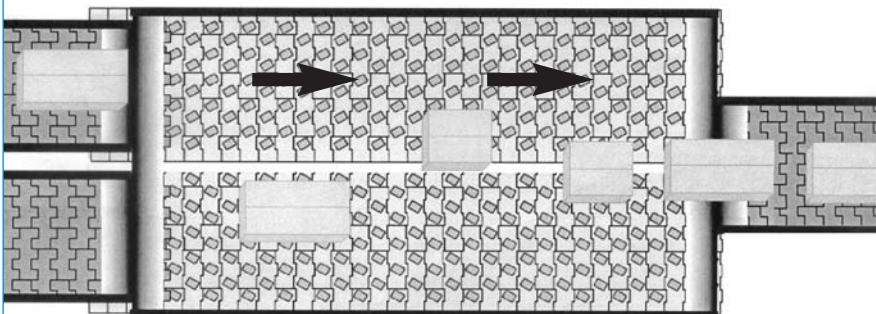

The two side-by-side angled roller belts direct products to the belt's center.

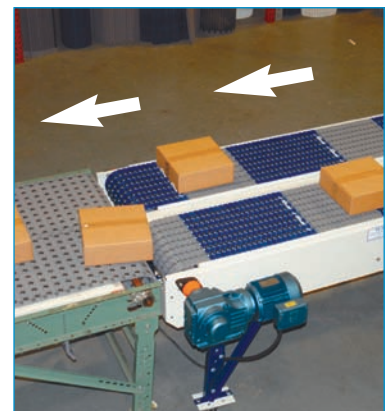

## Chordal Action

As a belt engages in the driving sprockets, a pulsation-like motion will occur. This pulsation is due to the chordal action, which is the rise and fall of the belt as it rotates **around** and **in** the teeth of a sprocket. It is a characteristic of all sprocket-driven belts. The amount of pulsation is inversely proportional to the amount of space between the belt and teeth of the sprockets. The smaller the space, the less pulsation there is. Thus the smaller the pitch, the less space there is between the pitches so there is less chordal action. Chordal action can also be reduced by increasing the number of teeth on a sprocket. The more teeth the less space there is for the belt to move around and in a sprocket. For example, a belt driven by a six-tooth sprocket has a pulsating speed variation of 13.4%, while a belt driven by a 19-tooth sprocket has a pulsation speed variation of only 1.36%. In conclusion, if your application requires a smooth transfer or product tipping or breaking is a concern, choose the smallest pitch belt available combined with the sprocket with the most teeth.

## Pitch

The pitch is the center-to-center distance between hinge rods in an assembled belt. A smaller pitch belt reduces the amount of chordal action. Smaller pitches also wrap the discharge sprockets more tightly reducing the gap at the discharge transfer points. For these two reasons, smaller pitch belts are recommended for applications with small and delicate products where product transfers and product tipping are a concern. Because smaller pitch belts have less chordal action they run smoother so they are also recommended for high-speed applications.

### \*\*Price Relativity Overall

The \$ (dollar sign) system is designed to help you compare the cost of a square foot of belt from one application to a square foot of belt in another application. Belts are divided into 6 different groups with one dollar sign being the least expensive and six dollar signs being the most expensive.

\$ – The least expensive belt.

\$\$\$\$\$\$ – The most expensive belt.

**Price Relativity Within This Table** – this column compares the belts listed on that page's table to one another.

## Polypropylene – Polyethylene – Acetal

CHARACTERISTIC	POLYPROPYLENE – PP	POLYETHYLENE – PE	ACETAL – A
Accumulation	Good accumulation properties	Not recommended for accumulation applications	Excellent accumulation and side-to-side transfer properties
Price	Less costly than the other two	Moderately priced versus the others	Costly compared to the others
Release	Good release characteristics	Excellent release characteristics	Excellent release characteristics
Strength	Good balance between moderate strength and lightweight material	Overall not as strong and lacks the pull strength of the polypropylene and acetal	Considerably stronger than polypropylene or polyethylene.  Acetal is very hard making it relatively cut and scratch resistant.
Temperature	+ 45 degrees to + 220 degrees F  Excellent in high temp applications	– 100 degrees to + 150 degrees F  A good alternative to the costly acetal in low temperature applications.	– 50 degrees to + 200 degrees F  Good impact strength even at low temperatures
Disadvantages	Becomes very brittle and weak below 45 degrees	Scratches and gouges easily  The rods tend to wear out quickly when exposed to abrasive particles.	Considerably heavier than the others which causes more belt wear and limits its use in longer run applications.



# THE TOP 10 BENEFITS of PlastiTrak

## Plasti-Trak Low Maintenance Plastic Belt Conveyors from New London Engineering

	BENEFIT	PLASTI-TRAK PLASTIC BELT SOLUTIONS
1.	Reduced maintenance and maintenance related costs.	<ul style="list-style-type: none"> <li>- Since Plasti-Trak belts are positively driven with sprockets rather than pulleys, belt tracking and belt tensioning tasks are eliminated. More importantly, costly ongoing roller replacement costs and time costs to repair dead zones* in roller conveyors are virtually eliminated.</li> <li>- Plastic belts require reduced maintenance – Just plug it in and let it spin!</li> </ul>
2.	More satisfied customers because more promised delivery dates are met	<ul style="list-style-type: none"> <li>- Unscheduled shutdowns are a primary reason promised delivery dates are not met. With Plasti-Trak, unscheduled shutdowns are virtually eliminated:               <ol style="list-style-type: none"> <li>1. Belts are positively driven with sprockets rather than pulleys so they will not walk, slip or mis-track and jam the production line.</li> <li>2. The system will not have to be shut down to repair unexpected dead zones*.</li> <li>3. Improved product orientation provides more consistent product spacing resulting in fewer line jams eliminating line jam related shutdowns.</li> </ol> </li> </ul>
3.	Improved production line flexibility (No Roller Spacing Issues)	<ul style="list-style-type: none"> <li>- On a traditional roller conveyor, product sizes are limited by the spacing of the rollers. If the product size changes, the line is shut down to re-space or re-place the rollers. These costly line changes are totally eliminated with Plasti-Trak because a Plasti-Trak belt is one smooth surface capable of handling various sizes and types of products on the same line.</li> </ul>
4.	Increased productivity	<ul style="list-style-type: none"> <li>- A Plasti-Trak belt acts as one continuous piece and not a series of individual rollers so there are no dead zones*. Dead zones* can lead to slugs*. Slugs can lead to jams, photo eye mis-reads, and inaccurate case counts which all lower productivity.</li> <li>- Since system jams are reduced, plant productivity increases because cases do not have to re-circulate through the system.</li> <li>- Since jams are virtually eliminated the labor cost to manually un-jam the system is also eliminated.</li> </ul>
5.	Reduced product loss and product damage	<ul style="list-style-type: none"> <li>- Unlike rollers and rubber belts, glue and tapes from boxes typically do not stick to plastic belts so product loss due to adhesion issues are reduced or eliminated.</li> <li>- Since slugs* and dead zones* have been eliminated, product damage from cases bumping into one another are also eliminated.</li> </ul>
6.	Replacement part costs are reduced	<ul style="list-style-type: none"> <li>- Since the belts are modular, only the damaged module needs to be replaced rather than the entire belt.</li> <li>- Since you are replacing only a small module, belts do not have to be re-tracked so the time to replace and to re-track an entire new belt is saved.</li> <li>- Since belts can't "walk" and cause trim edge damage they last longer. A plastic belt will typically last 3 times longer than a traditional rubber belt in the same application.</li> </ul>
7.	Reduced insurance claims and Lost Time Accidents	<ul style="list-style-type: none"> <li>- Safety is improved because employees will have a smooth, flat platform to walk on versus the unsafe, moving and rolling surface of a roller conveyor.</li> </ul>
8.	ACT System Technology	<ul style="list-style-type: none"> <li>- The Model 2000 includes New London's exclusive ACT System (Application Change Technology). This system provides the end user with the flexibility to exchange the existing belt with another if the application or product changes in the future. The safety and flexibility of this feature has the potential to save the end user thousands of dollars in future conveyor purchases. (See page 1)</li> </ul>
9.	Quiet, more worker friendly environment	<ul style="list-style-type: none"> <li>- As roller bearings wear they have a tendency to make a "humming" or "whistling" noise that can be irritating. This noise is eliminated with Plasti-Trak.</li> </ul>
10.	Opportunity	<ul style="list-style-type: none"> <li>- With your skilled maintenance department spending less time maintaining your system, their time can be dedicated to other productivity opportunities.</li> </ul>

### How Much Can You Save With a Plasti-Trak Conveyor?

Choosing a conveyor system based on a lower initial price can prove costly over the life of the system. The initial price for a powered roller or gravity roller system might be lower than Plasti-Trak but expenses add up quickly taking into account maintenance, loss of production and product damage. Research completed by a leading plastic belt manufacturer concluded the annual expenses to operate a roller conveyor system can be as high as \$50/foot of conveyor.

\*Dead zones – dead zones occur when rollers stop turning typically due bearing failures.

\*Slugs – slugs are large groups of cases lumped together rather than being evenly spaced along the line.

# CUSTOM AND STANDARD CONVEYORS

**We are a full line conveyor supplier specializing in engineering high quality, quick delivery conveyors.**

- Accumulation Conveyors
- Belt Driven Live Roller Conveyors
- Bulk Material Handling Conveyors
- Cleated Belt Parts Conveyors
- Chain Driven Live Roller Conveyors
- Chain Transfers
- Drag Conveyors
- Floor-to-Floor Conveyors
- Gravity Roller
- Magnetic Conveyors
- Pallet Dispensers
- Power Roller Conveyors
- PlastiTrak - A full line of plastic belt conveyors
- Quick Start Electrical Controls
- Slat Conveyors
- Slider Bed Conveyors
- Specialty Conveyors
- SteefTrak - Hinged Steel Belt Conveyors
- ToughTrak - Tough and durable thin line conveyors
- Turntables
- UpTime Express - 24 hour shipments
- V-Belt Conveyors
- Wire Mesh Conveyors

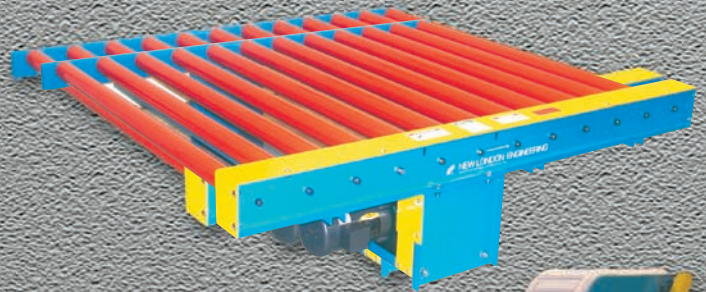

 **New London  
Engineering**  
Quality Conveyors Since 1948

1700 Division Street • New London, WI 54961  
800-437-1994 • 920-982-4030 • fax: 920-982-6800

Brochure #PT-05-07

[www.nleco.com](http://www.nleco.com)