

MODEL 505

TOP MOUNT DRIVE

HEAVY DRIVE SHAFT M505 MEDIUM DUTY CLEATED INCLINE CONVEYOR

This units deep frame, 3" high cleats, 6" high Side rails and large drive pulley are designed to move larger products easily and efficiently up inclines. This sturdy, solid conveyor is built to last and withstand heavy usage.

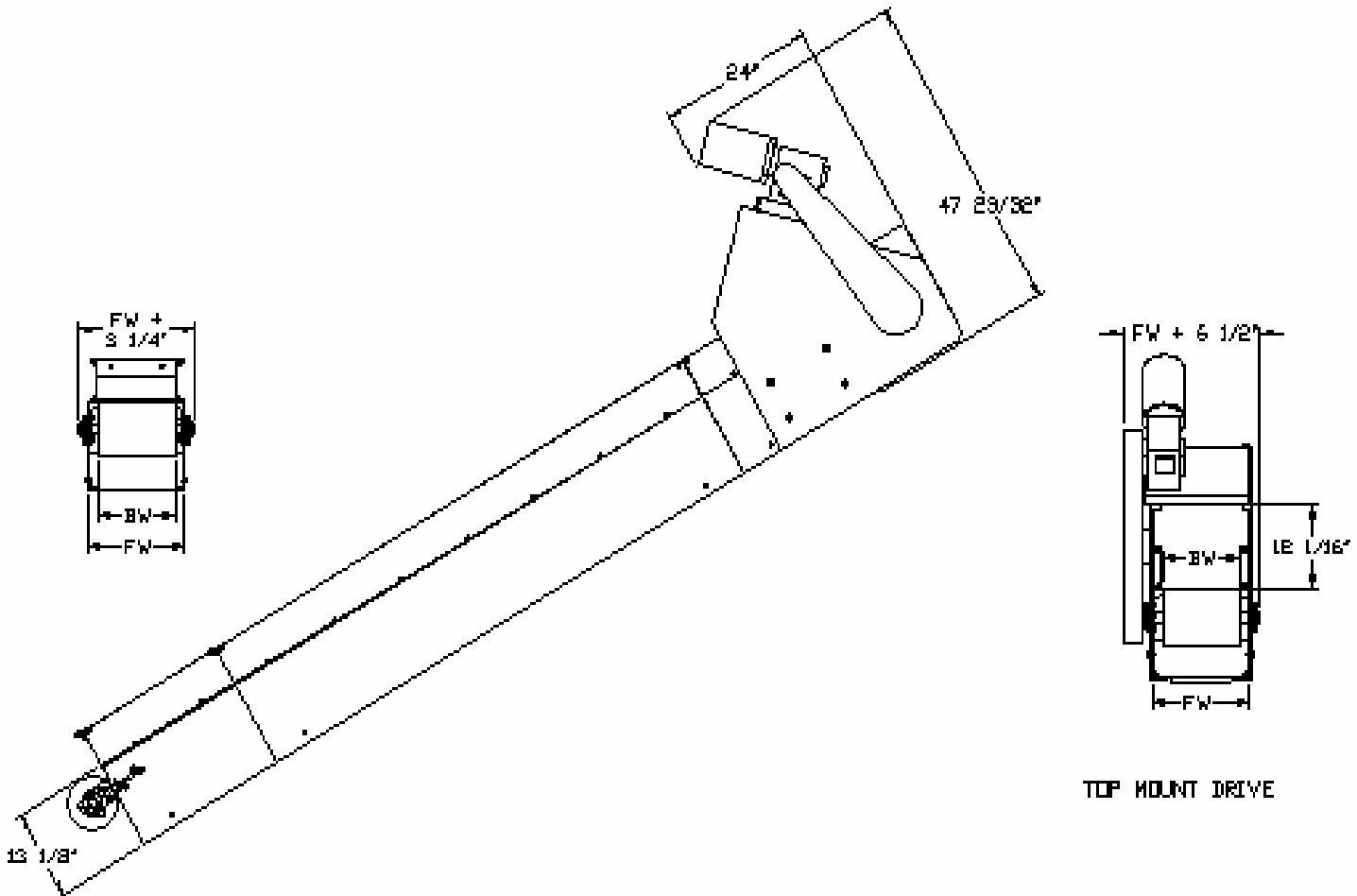

TOP MOUNT DRIVE

1700 Division Street, New London, WI 54961

Phone: (800) 437-1994

Fax: (920) 982-6800

www.nleco.com